

Slewing tower crane

WOLFF 6023 clear

Technical information

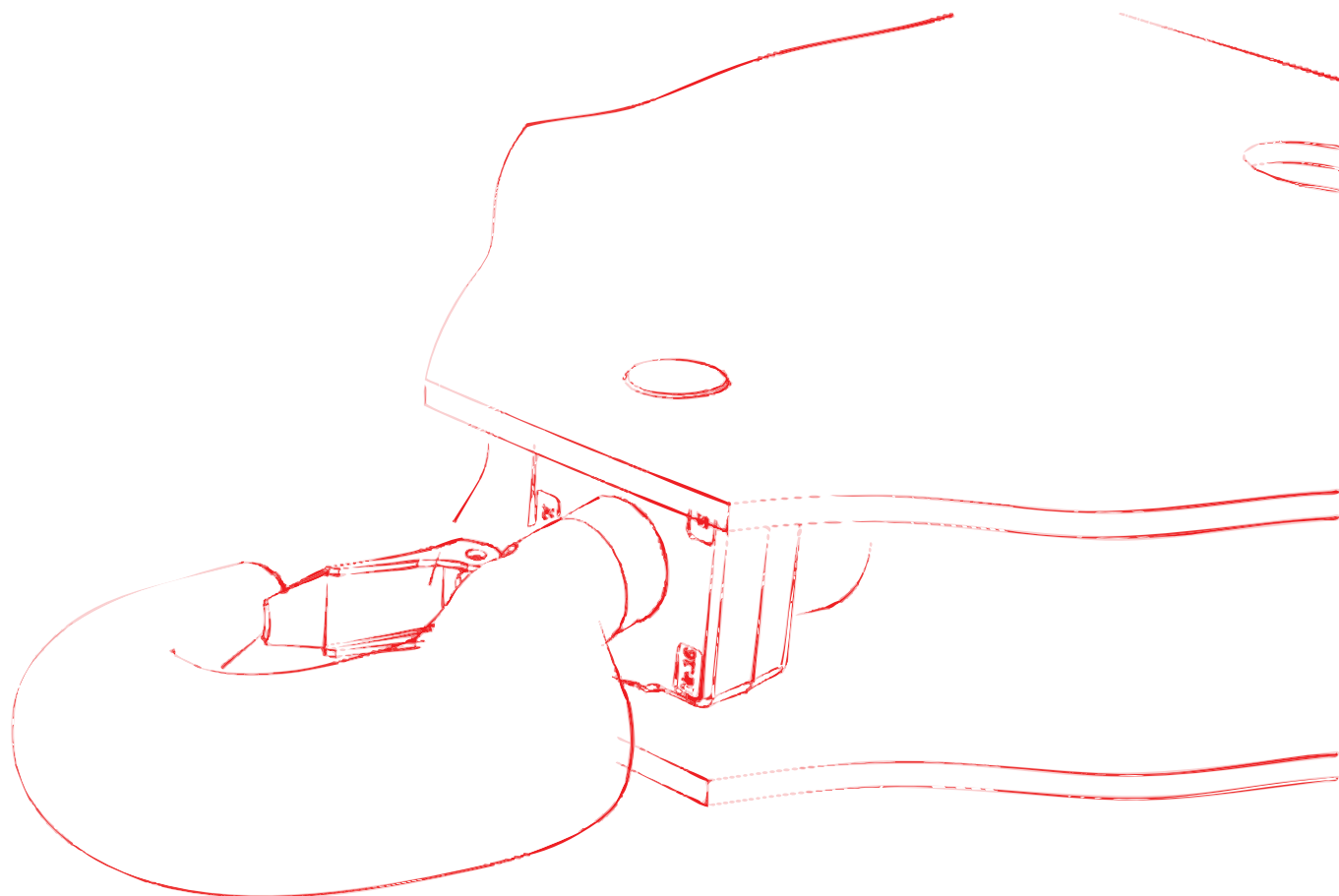

English

English



Published by

WOLFFKRAN GmbH

Austraße 72

74076 Heilbronn

Germany

Phone +49 7131 9815 0

Fax +49 7131 9815 355

www.wolffkran.com

info@wolffkran.de

Copyright

This documentation including all of its subsections is protected by copyright laws.

Any type of use or modification outside of the stringent limits of the copyright laws without permission of WOLFFKRAN GmbH is prohibited and subject to penalties.

This applies particularly for copying, translation, microfilming and storage and processing in electronic systems.

At the time of printing, the information, data, illustrations and notes comprised in this manual were up-to-date.

Subject to change of design, error and typos.

Stand: 03/2017

Table of contents

| | | |
|------|---|----|
| 1 | Schedule drawing | 5 |
| 1.1 | Schedule drawing WOLFF 6023.6clear | 5 |
| 1.2 | Schedule drawing WOLFF 6023.8clear | 6 |
| 2 | Load carrying capacities | 7 |
| 2.1 | Table of load carrying capacities, WOLFF 6023.6 clear (6.2 t) | 8 |
| 2.2 | Table of load carrying capacities (kg) in meter intervals, WOLFF 6023.6 clear (6.2 t, 2 fall operation) | 9 |
| 2.3 | Load capacity tables WOLFF 6023.8 clear (8.5 t) | 10 |
| 2.4 | Table of load carrying capacities (kg) in meter intervals, WOLFF 6023.8 clear (8.5 t, 2 fall operation) | 11 |
| 3 | Tower combinations | 12 |
| 3.1 | Tower combinations on foundation (slewing section with TFS 20 - connection) | 13 |
| 3.2 | Tower combinations on foundation (slewing section with UV 20 / TV 20 - connection) | 18 |
| 3.3 | Tower combinations on cross frame (slewing section with TFS 20 - connection) | 22 |
| 3.4 | Tower combinations on cross frame (slewing section with UV 20 / TV 20 - connection) | 28 |
| 3.5 | Tower combinations on cross frame element (slewing section with TFS 20 - connection) | 34 |
| 3.6 | Tower combinations on cross frame element (slewing section with UV 20 / TV 20 - connection) | 36 |
| 3.7 | Tower combinations on mobile cross frame (slewing section with TFS 20 - connection) | 38 |
| 3.8 | Tower combinations on mobile cross frame (slewing section with UV 20 / TV 20 - connection) | 41 |
| 3.9 | Tower combinations on undercarriage (slewing section with TFS 20 - connection) | 44 |
| 3.10 | Tower combinations on undercarriage (slewing section with UV 20 / TV 20 - connection) | 46 |
| 4 | Foundation loads / central ballast weights / corner loads in compliance with EN 14439 / EN 13001 | 48 |
| 4.1 | Foundation loads jib 25 m - 60 m | 50 |
| 5 | Operating speeds | 51 |
| 6 | Package list | 54 |
| 6.1 | Package list 6023 | 54 |
| 7 | Assembly weights | 56 |

| | | |
|-------|---|----|
| 7.1 | Counterweight blocks | 56 |
| 7.1.1 | Counterweight block, 2.7 t | 57 |
| 7.1.2 | Counterweight block, 3.7 t | 58 |
| 7.2 | Total weight jib assembly | 59 |
| 7.3 | Assembly weight slewing section | 60 |
| 7.4 | Assembly weight cross frame | 61 |
| 7.5 | Assembly weights traveling cross frame | 63 |
| 7.6 | Assembly weight cross frame elements | 65 |
| 7.7 | Assembly weight undercarriage | 66 |
| 7.8 | Required hook height for mobile cranes | 67 |
| 8 | Assembly diagrams | 68 |
| 8.1 | Jib attachment diagram | 68 |
| 8.1.1 | Trolley jib - attachment diagram 60 m to 50 m | 69 |
| 8.1.2 | Trolley jib - attachment diagram 47.5 m to 37.5 m | 70 |
| 8.1.3 | Trolley jib - attachment diagram 35 m to 25 m | 71 |
| 8.2 | Trolley jib mounting rig | 72 |
| 8.3 | Arrangement of standard railings | 73 |
| 8.3.1 | Standard railings (NG) and accessories | 73 |
| 8.3.2 | Arrangement of standard railings | 74 |
| 9 | Suitable climbing devices | 76 |
| 9.1 | Outer climbing devices | 77 |
| 9.1.1 | Outer climbing device KWH 20.3 / KWH 20.3.1 | 78 |
| 9.1.2 | Außenkletterwerk KWH 20.6 / KWH 20.6.1 / KWH 20.6.2 | 79 |
| 9.2 | Inner climbing devices | 80 |
| 9.2.1 | Inner climbing device KSH 20 M | 81 |
| 9.2.2 | Inner climbing device KSH 20 SH | 83 |
| 10 | Arrangement of counterweight blocks | 86 |

1 Schedule drawing

1.1 Schedule drawing WOLFF 6023.6clear

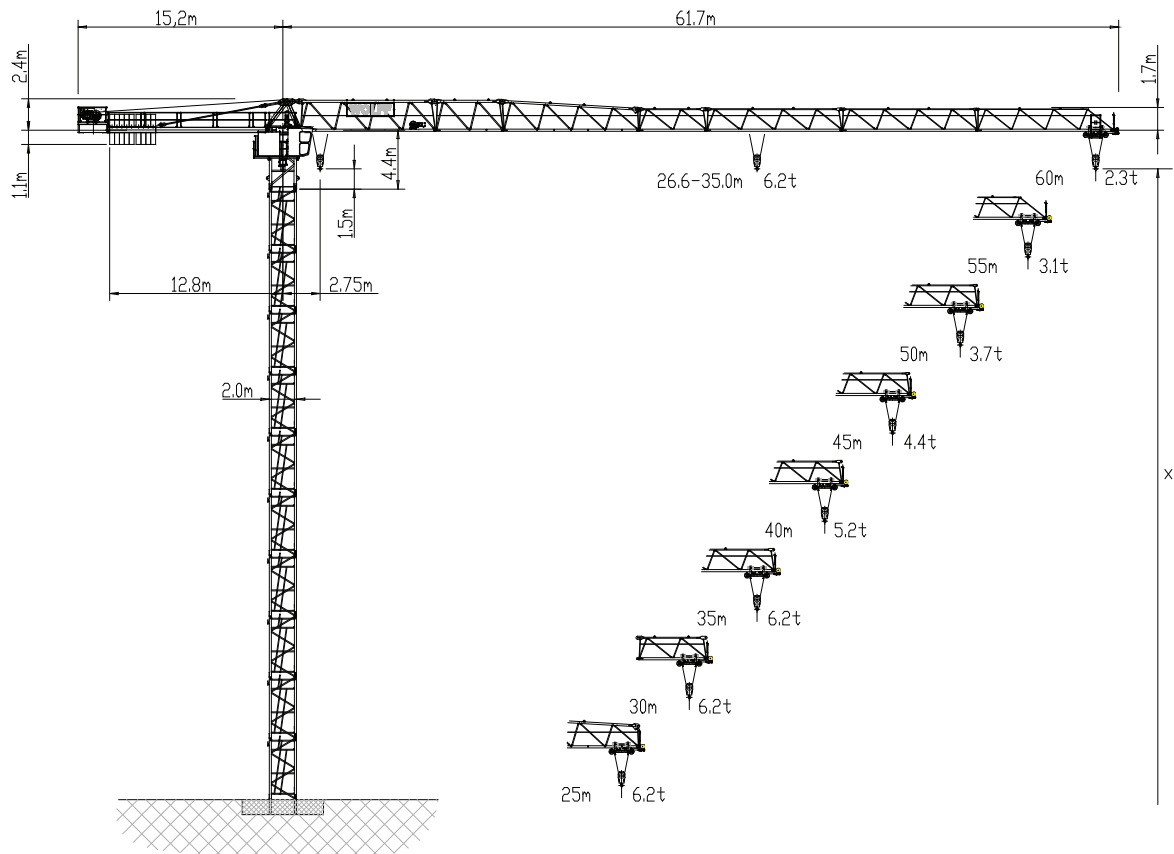

| | |
|-----|-------------------------------|
| [X] | max. hook height above ground |
|-----|-------------------------------|

Data WOLFF 6023.6clear

| Item | Data |
|----------------------|---|
| Crane type | BGL GROUP C.0.10.0180 |
| Design | Overhead travelling crane with top slewing trolley jib, with climbing feature |
| Type of setup | Stationary or travelling |
| Basis of calculation | EN 14439 (C25) |
| Payload torque | max. 2170 kNm |
| Hoist winch | Hw 628FU |

1 Schedule drawing

1.2 Schedule drawing WOLFF 6023.8clear

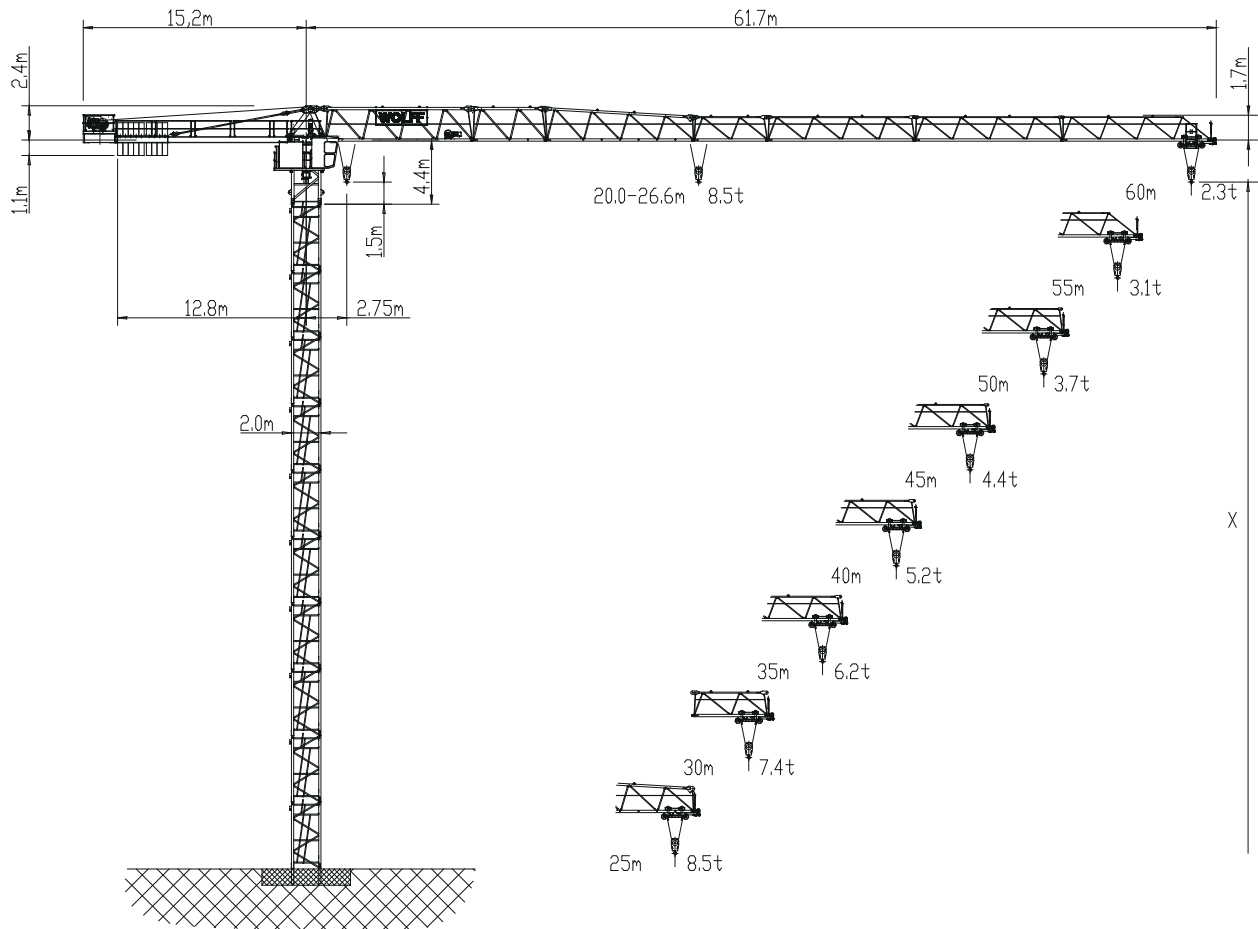

[X] max. hook height above ground

Data WOLFF 6023.8clear

| Item | Data |
|----------------------|---|
| Crane type | BGL GROUP C.0.10.0180 |
| Design | Overhead travelling crane with top slewing trolley jib, with climbing feature |
| Type of setup | Stationary or travelling |
| Basis of calculation | EN 14439 (C25) |
| Payload torque | max. 2260 kNm |
| Hoist winch | Hw 845FU / Hw 875FU |

2 Load carrying capacities



NOTICE

WOLFF-Boost

With the WOLFF-Boost function, the load is allowed to exceed the load torque range specified for the lifting capacities by up to 10%. This is, however, subject to the restriction that hoisting gear and trolley drive (trolley crane) respectively hoisting gear and derricking gear (luffing crane) must only be moved alternately.

2 Load carrying capacities

2.1 Table of load carrying capacities, WOLFF 6023.6 clear (6.2 t)

|  6.2 t | | Operating radius [m] | 20.0 | 25.0 | 27.5 | 30.0 | 32.5 | 35.0 | 37.5 | 40.0 | 42.5 | 45.0 | 47.5 | 50.0 | 52.5 | 55.0 | 57.5 | 60.0 | LCC [t] | |
|--|------|----------------------|------------------------|------|------|------|------|------|------|------|------|------|------|------|------|------|------|------|---------|--|
| | | | | | | | | | | | | | | | | | | | | |
| JL [m] | 60.0 | 2.75 - 26.6 | 6.2 | 6.2 | 6.0 | 5.4 | 4.9 | 4.5 | 4.2 | 3.9 | 3.6 | 3.3 | 3.1 | 2.9 | 2.7 | 2.6 | 2.4 | 2.3 | | |
| | 57.5 | 2.75 - 28.8 | 6.2 | 6.2 | 6.2 | 5.9 | 5.4 | 5.0 | 4.6 | 4.2 | 3.9 | 3.7 | 3.4 | 3.2 | 3.0 | 2.9 | 2.7 | | | |
| | 55.0 | 2.75 - 30.6 | 6.2 | 6.2 | 6.2 | 6.2 | 5.8 | 5.3 | 4.9 | 4.6 | 4.2 | 4.0 | 3.7 | 3.5 | 3.3 | 3.1 | | | | |
| | 52.5 | 2.75 - 31.5 | 6.2 | 6.2 | 6.2 | 6.2 | 6.0 | 5.5 | 5.1 | 4.7 | 4.4 | 4.1 | 3.8 | 3.6 | 3.4 | | | | | |
| | 50.0 | 2.75 - 32.1 | 6.2 | 6.2 | 6.2 | 6.2 | 6.1 | 5.6 | 5.2 | 4.8 | 4.5 | 4.2 | 3.9 | 3.7 | | | | | | |
| | 47.5 | 2.75 - 32.6 | 6.2 | 6.2 | 6.2 | 6.2 | 6.2 | 5.7 | 5.3 | 4.9 | 4.6 | 4.3 | 4.0 | | | | | | | |
| | 45.0 | 2.75 - 33.4 | 6.2 | 6.2 | 6.2 | 6.2 | 6.2 | 5.9 | 5.4 | 5.1 | 4.7 | 4.4 | | | | | | | | |
| | 42.5 | 2.75 - 34.0 | 6.2 | 6.2 | 6.2 | 6.2 | 6.2 | 6.0 | 5.5 | 5.2 | 4.8 | | | | | | | | | |
| | 40.0 | 2.75 - 34.3 | 6.2 | 6.2 | 6.2 | 6.2 | 6.2 | 6.1 | 5.6 | 5.2 | | | | | | | | | | |
| | 37.5 | 2.75 - 34.8 | 6.2 | 6.2 | 6.2 | 6.2 | 6.2 | 6.2 | 5.7 | | | | | | | | | | | |
| | 35.0 | 2.75 - 35.0 | 6.2 | 6.2 | 6.2 | 6.2 | 6.2 | 6.2 | | | | | | | | | | | | |
| | 32.5 | 2.75 - 32.5 | 6.2 | 6.2 | 6.2 | 6.2 | 6.2 | | | | | | | | | | | | | |
| | 30.0 | 2.75 - 30.0 | 6.2 | 6.2 | 6.2 | 6.2 | | | | | | | | | | | | | | |
| | 27.5 | 2.75 - 27.5 | 6.2 | 6.2 | 6.2 | | | | | | | | | | | | | | | |
| | 25.0 | 2.75 - 25.0 | 6.2 | 6.2 | | | | | | | | | | | | | | | | |
| JL | | | Jib length | | | | | | | | | | | | | | | | | |
| LCC | | | Load carrying capacity | | | | | | | | | | | | | | | | | |

The load carrying capacity is related to a hook range of 42.0 m. Hook ranges greater than that reduce the maximum load carrying capacity by the weight of the additional hoisting ropes (2 fall operation = 2.5 kg per meter of the hook range).

2.2 Table of load carrying capacities (kg) in meter intervals, WOLFF 6023.6 clear (6.2 t, 2 fall operation)

| Operating radius [m] | Jib length [m] | | | | | | | | | | | | | | | |
|-------------------------|----------------|-------------|-------------|-------------|-------------|-------------|-------------|-------------|-------------|-------------|-------------|-------------|-------------|-------------|-------------|-------------|
| | 25.0 | 27.5 | 30.0 | 32.5 | 35.0 | 37.5 | 40.0 | 42.5 | 45.0 | 47.5 | 50.0 | 52.5 | 55.0 | 57.5 | 60.0 | |
| 20.0 | 6200 | 6200 | 6200 | 6200 | 6200 | 6200 | 6200 | 6200 | 6200 | 6200 | 6200 | 6200 | 6200 | 6200 | 6200 | |
| 21.0 | 6200 | 6200 | 6200 | 6200 | 6200 | 6200 | 6200 | 6200 | 6200 | 6200 | 6200 | 6200 | 6200 | 6200 | 6200 | |
| 22.0 | 6200 | 6200 | 6200 | 6200 | 6200 | 6200 | 6200 | 6200 | 6200 | 6200 | 6200 | 6200 | 6200 | 6200 | 6200 | |
| 23.0 | 6200 | 6200 | 6200 | 6200 | 6200 | 6200 | 6200 | 6200 | 6200 | 6200 | 6200 | 6200 | 6200 | 6200 | 6200 | |
| 24.0 | 6200 | 6200 | 6200 | 6200 | 6200 | 6200 | 6200 | 6200 | 6200 | 6200 | 6200 | 6200 | 6200 | 6200 | 6200 | |
| 25.0 | 6200 | 6200 | 6200 | 6200 | 6200 | 6200 | 6200 | 6200 | 6200 | 6200 | 6200 | 6200 | 6200 | 6200 | 6200 | |
| 26.0 | | 6200 | 6200 | 6200 | 6200 | 6200 | 6200 | 6200 | 6200 | 6200 | 6200 | 6200 | 6200 | 6200 | 6200 | |
| 27.0 | | 6200 | 6200 | 6200 | 6200 | 6200 | 6200 | 6200 | 6200 | 6200 | 6200 | 6200 | 6200 | 6200 | 6090 | |
| 27.5 | | 6200 | 6200 | 6200 | 6200 | 6200 | 6200 | 6200 | 6200 | 6200 | 6200 | 6200 | 6200 | 6200 | 6000 | |
| 28.0 | | | 6200 | 6200 | 6200 | 6200 | 6200 | 6200 | 6200 | 6200 | 6200 | 6200 | 6200 | 6200 | 5840 | |
| 29.0 | | | 6200 | 6200 | 6200 | 6200 | 6200 | 6200 | 6200 | 6200 | 6200 | 6200 | 6200 | 6140 | 5610 | |
| 30.0 | | | 6200 | 6200 | 6200 | 6200 | 6200 | 6200 | 6200 | 6200 | 6200 | 6200 | 6200 | 5900 | 5400 | |
| 31.0 | | | | 6200 | 6200 | 6200 | 6200 | 6200 | 6200 | 6200 | 6200 | 6200 | 6120 | 5690 | 5200 | |
| 32.0 | | | | 6200 | 6200 | 6200 | 6200 | 6200 | 6200 | 6200 | 6200 | 6090 | 5900 | 5490 | 5010 | |
| 32.5 | | | | 6200 | 6200 | 6200 | 6200 | 6200 | 6200 | 6200 | 6100 | 6000 | 5800 | 5400 | 4900 | |
| 33.0 | | | | | 6200 | 6200 | 6200 | 6200 | 6200 | 6110 | 6020 | 5880 | 5700 | 5300 | 4840 | |
| 34.0 | | | | | 6200 | 6200 | 6200 | 6200 | 6080 | 5910 | 5820 | 5690 | 5510 | 5120 | 4670 | |
| 35.0 | | | | | 6200 | 6200 | 6060 | 6000 | 5900 | 5700 | 5600 | 5500 | 5300 | 5000 | 4500 | |
| 36.0 | | | | | | 5970 | 5870 | 5810 | 5700 | 5450 | 5450 | 5330 | 5160 | 4790 | 4370 | |
| 37.0 | | | | | | 5790 | 5690 | 5630 | 5520 | 5280 | 5280 | 5160 | 5000 | 4640 | 4230 | |
| 37.5 | | | | | | 5700 | 5600 | 5500 | 5400 | 5200 | 5200 | 5100 | 4900 | 4600 | 4200 | |
| 38.0 | | | | | | | 5520 | 5460 | 5360 | 5120 | 5120 | 5000 | 4840 | 4500 | 4090 | |
| 39.0 | | | | | | | 5350 | 5300 | 5200 | 4970 | 4970 | 4850 | 4700 | 4360 | 3970 | |
| 40.0 | | | | | | | 5200 | 5200 | 5100 | 4900 | 4800 | 4700 | 4600 | 4200 | 3900 | |
| 41.0 | | | | | | | | 5000 | 4910 | 4760 | 4690 | 4580 | 4430 | 4110 | 3740 | |
| 42.0 | | | | | | | | 4870 | 4770 | 4630 | 4560 | 4450 | 4310 | 3990 | 3630 | |
| 42.5 | | | | | | | | 4800 | 4700 | 4600 | 4500 | 4400 | 4200 | 3900 | 3600 | |
| 43.0 | | | | | | | | | 4640 | 4500 | 4430 | 4330 | 4190 | 3880 | 3530 | |
| 44.0 | | | | | | | | | 4520 | 4380 | 4310 | 4210 | 4080 | 3770 | 3430 | |
| 45.0 | | | | | | | | | 4400 | 4300 | 4200 | 4100 | 4000 | 3700 | 3300 | |
| 46.0 | | | | | | | | | | 4160 | 4090 | 3990 | 3860 | 3580 | 3240 | |
| 47.0 | | | | | | | | | | 4050 | 3990 | 3890 | 3760 | 3480 | 3160 | |
| 47.5 | | | | | | | | | | 4000 | 3900 | 3800 | 3700 | 3400 | 3100 | |
| 48.0 | | | | | | | | | | | 3890 | 3790 | 3670 | 3390 | 3080 | |
| 49.0 | | | | | | | | | | | 3790 | 3700 | 3580 | 3310 | 3000 | |
| 50.0 | | | | | | | | | | | 3700 | 3600 | 3500 | 3200 | 2900 | |
| 51.0 | | | | | | | | | | | | 3520 | 3410 | 3150 | 2850 | |
| 52.0 | | | | | | | | | | | | 3440 | 3330 | 3070 | 2780 | |
| 52.5 | | | | | | | | | | | | 3400 | 3300 | 3000 | 2750 | |
| 53.0 | | | | | | | | | | | | | 3250 | 3000 | 2710 | |
| 54.0 | | | | | | | | | | | | | 3170 | 2930 | 2640 | |
| 55.0 | | | | | | | | | | | | | | 3100 | 2900 | 2600 |
| 56.0 | | | | | | | | | | | | | | | 2790 | 2520 |
| 57.0 | | | | | | | | | | | | | | | 2730 | 2460 |
| 57.5 | | | | | | | | | | | | | | | 2700 | 2450 |
| 58.0 | | | | | | | | | | | | | | | | 2410 |
| 59.0 | | | | | | | | | | | | | | | | 2350 |
| 60.0 | | | | | | | | | | | | | | | | 2300 |

2 Load carrying capacities

2.3 Load capacity tables WOLFF 6023.8 clear (8.5 t)

|  8.5 t | | Operating radius [m] | 20.0 | 25.0 | 27.5 | 30.0 | 32.5 | 35.0 | 37.5 | 40.0 | 42.5 | 45.0 | 47.5 | 50.0 | 52.5 | 55.0 | 57.5 | 60.0 | LCC [t] |
|--|------|----------------------|------------------------|------------|------------|------------|------------|------------|------------|------------|------------|------------|------------|------------|------------|------------|------------|------------|---------|
| | | | | | | | | | | | | | | | | | | | |
| JL [m] | 60.0 | 2.75 - 20.0 | 8.5 | 6.6 | 6.0 | 5.4 | 4.9 | 4.5 | 4.2 | 3.9 | 3.6 | 3.3 | 3.1 | 2.9 | 2.7 | 2.6 | 2.4 | 2.3 | |
| | 57.5 | 2.75 - 21.6 | 8.5 | 7.3 | 6.5 | 5.9 | 5.4 | 5.0 | 4.6 | 4.2 | 3.9 | 3.7 | 3.4 | 3.2 | 3.0 | 2.9 | 2.7 | | |
| | 55.0 | 2.75 - 23.1 | 8.5 | 7.8 | 7.0 | 6.4 | 5.8 | 5.3 | 4.9 | 4.6 | 4.2 | 4.0 | 3.7 | 3.5 | 3.3 | 3.1 | | | |
| | 52.5 | 2.75 - 23.7 | 8.5 | 8.0 | 7.2 | 6.6 | 6.0 | 5.5 | 5.1 | 4.7 | 4.4 | 4.1 | 3.8 | 3.6 | 3.4 | | | | |
| | 50.0 | 2.75 - 24.2 | 8.5 | 8.2 | 7.4 | 6.7 | 6.1 | 5.6 | 5.2 | 4.8 | 4.5 | 4.2 | 3.9 | 3.7 | | | | | |
| | 47.5 | 2.75 - 24.5 | 8.5 | 8.3 | 7.5 | 6.8 | 6.2 | 5.7 | 5.3 | 4.9 | 4.6 | 4.3 | 4.0 | | | | | | |
| | 45.0 | 2.75 - 25.2 | 8.5 | 8.5 | 7.7 | 7.0 | 6.4 | 5.9 | 5.4 | 5.1 | 4.7 | 4.4 | | | | | | | |
| | 42.5 | 2.75 - 25.6 | 8.5 | 8.5 | 7.9 | 7.1 | 6.5 | 6.0 | 5.5 | 5.2 | 4.8 | | | | | | | | |
| | 40.0 | 2.75 - 25.8 | 8.5 | 8.5 | 7.9 | 7.2 | 6.6 | 6.1 | 5.6 | 5.2 | | | | | | | | | |
| | 37.5 | 2.75 - 26.2 | 8.5 | 8.5 | 8.1 | 7.3 | 6.7 | 6.2 | 5.7 | | | | | | | | | | |
| | 35.0 | 2.75 - 26.3 | 8.5 | 8.5 | 8.1 | 7.4 | 6.7 | 6.2 | | | | | | | | | | | |
| | 32.5 | 2.75 - 26.6 | 8.5 | 8.5 | 8.2 | 7.4 | 6.8 | | | | | | | | | | | | |
| | 30.0 | 2.75 - 26.5 | 8.5 | 8.5 | 8.2 | 7.4 | | | | | | | | | | | | | |
| | 27.5 | 2.75 - 26.3 | 8.5 | 8.5 | 8.1 | | | | | | | | | | | | | | |
| | 25.0 | 2.75 - 25.0 | 8.5 | 8.5 | | | | | | | | | | | | | | | |
| JL | | | Jib length | | | | | | | | | | | | | | | | |
| LCC | | | Load carrying capacity | | | | | | | | | | | | | | | | |





The load carrying capacity is related to a hook range of 42.0 m. Hook ranges greater than that reduce the maximum load carrying capacity by the weight of the additional hoisting ropes (2 fall operation = 2.5 kg per meter of the hook range).

2.4 Table of load carrying capacities (kg) in meter intervals, WOLFF 6023.8 clear (8.5 t, 2 fall operation)

| Operating radius [m] | Jib length | | | | | | | | | | | | | | |
|-------------------------|-------------|-------------|-------------|-------------|-------------|-------------|-------------|-------------|-------------|-------------|-------------|-------------|-------------|-------------|-------------|
| | 25.0 | 27.5 | 30.0 | 32.5 | 35.0 | 37.5 | 40.0 | 42.5 | 45.0 | 47.5 | 50.0 | 52.5 | 55.0 | 57.5 | 60.0 |
| 20.0 | 8500 | 8500 | 8500 | 8500 | 8500 | 8500 | 8500 | 8500 | 8500 | 8500 | 8500 | 8500 | 8500 | 8500 | 8500 |
| 21.0 | 8500 | 8500 | 8500 | 8500 | 8500 | 8500 | 8500 | 8500 | 8500 | 8500 | 8500 | 8500 | 8500 | 8500 | 8060 |
| 22.0 | 8500 | 8500 | 8500 | 8500 | 8500 | 8500 | 8500 | 8500 | 8500 | 8500 | 8500 | 8500 | 8500 | 8350 | 7650 |
| 23.0 | 8500 | 8500 | 8500 | 8500 | 8500 | 8500 | 8500 | 8500 | 8500 | 8500 | 8500 | 8500 | 8500 | 7950 | 7290 |
| 24.0 | 8500 | 8500 | 8500 | 8500 | 8500 | 8500 | 8500 | 8500 | 8500 | 8500 | 8500 | 8390 | 8140 | 7590 | 6950 |
| 25.0 | 8500 | 8500 | 8500 | 8500 | 8500 | 8500 | 8500 | 8500 | 8500 | 8320 | 8200 | 8020 | 7780 | 7250 | 6640 |
| 26.0 | 8500 | 8500 | 8500 | 8500 | 8500 | 8500 | 8430 | 8350 | 8200 | 7970 | 7850 | 7680 | 7450 | 6940 | 6350 |
| 27.0 | | 8260 | 8310 | 8350 | 8270 | 8230 | 8090 | 8010 | 7870 | 7640 | 7530 | 7370 | 7140 | 6650 | 6090 |
| 27.5 | | 8100 | 8150 | 8180 | 8110 | 8060 | 7930 | 7850 | 7710 | 7490 | 7380 | 7220 | 7000 | 6520 | 5960 |
| 28.0 | | | 7990 | 8020 | 7950 | 7910 | 7770 | 7700 | 7560 | 7340 | 7240 | 7080 | 6860 | 6390 | 5840 |
| 29.0 | | | 7680 | 7720 | 7650 | 7610 | 7480 | 7410 | 7270 | 7060 | 6960 | 6800 | 6600 | 6140 | 5610 |
| 30.0 | | | 7400 | 7430 | 7370 | 7330 | 7200 | 7130 | 7000 | 6800 | 6700 | 6550 | 6350 | 5910 | 5400 |
| 31.0 | | | | 7170 | 7100 | 7060 | 6940 | 6880 | 6750 | 6550 | 6460 | 6310 | 6120 | 5690 | 5200 |
| 32.0 | | | | 6920 | 6860 | 6820 | 6700 | 6640 | 6510 | 6330 | 6230 | 6090 | 5900 | 5490 | 5010 |
| 32.5 | | | | 6800 | 6740 | 6700 | 6580 | 6520 | 6400 | 6220 | 6120 | 5980 | 5800 | 5390 | 4920 |
| 33.0 | | | | | 6620 | 6590 | 6470 | 6410 | 6290 | 6110 | 6020 | 5880 | 5700 | 5300 | 4840 |
| 34.0 | | | | | 6410 | 6370 | 6260 | 6200 | 6080 | 5910 | 5820 | 5690 | 5510 | 5120 | 4670 |
| 35.0 | | | | | 6200 | 6160 | 6060 | 6000 | 5890 | 5710 | 5630 | 5500 | 5330 | 4950 | 4510 |
| 36.0 | | | | | | 5970 | 5870 | 5810 | 5700 | 5530 | 5450 | 5330 | 5160 | 4790 | 4370 |
| 37.0 | | | | | | 5790 | 5690 | 5630 | 5520 | 5360 | 5280 | 5160 | 5000 | 4640 | 4230 |
| 37.5 | | | | | | 5700 | 5600 | 5550 | 5440 | 5280 | 5200 | 5080 | 4920 | 4570 | 4160 |
| 38.0 | | | | | | | 5520 | 5460 | 5360 | 5200 | 5120 | 5000 | 4840 | 4500 | 4090 |
| 39.0 | | | | | | | 5350 | 5300 | 5200 | 5050 | 4970 | 4850 | 4700 | 4360 | 3970 |
| 40.0 | | | | | | | 5200 | 5150 | 5050 | 4900 | 4830 | 4710 | 4560 | 4230 | 3850 |
| 41.0 | | | | | | | | 5000 | 4910 | 4760 | 4690 | 4580 | 4430 | 4110 | 3740 |
| 42.0 | | | | | | | | 4870 | 4770 | 4630 | 4560 | 4450 | 4310 | 3990 | 3630 |
| 42.5 | | | | | | | | 4800 | 4710 | 4560 | 4490 | 4390 | 4250 | 3940 | 3580 |
| 43.0 | | | | | | | | | 4640 | 4500 | 4430 | 4330 | 4190 | 3880 | 3530 |
| 44.0 | | | | | | | | | 4520 | 4380 | 4310 | 4210 | 4080 | 3770 | 3430 |
| 45.0 | | | | | | | | | 4400 | 4270 | 4200 | 4100 | 3970 | 3670 | 3330 |
| 46.0 | | | | | | | | | | 4160 | 4090 | 3990 | 3860 | 3580 | 3240 |
| 47.0 | | | | | | | | | | 4050 | 3990 | 3890 | 3760 | 3480 | 3160 |
| 47.5 | | | | | | | | | | 4000 | 3940 | 3840 | 3720 | 3440 | 3120 |
| 48.0 | | | | | | | | | | | 3890 | 3790 | 3670 | 3390 | 3080 |
| 49.0 | | | | | | | | | | | 3790 | 3700 | 3580 | 3310 | 3000 |
| 50.0 | | | | | | | | | | | 3700 | 3610 | 3490 | 3230 | 2920 |
| 51.0 | | | | | | | | | | | | 3520 | 3410 | 3150 | 2850 |
| 52.0 | | | | | | | | | | | | 3440 | 3330 | 3070 | 2780 |
| 52.5 | | | | | | | | | | | | 3400 | 3290 | 3030 | 2740 |
| 53.0 | | | | | | | | | | | | | 3250 | 3000 | 2710 |
| 54.0 | | | | | | | | | | | | | 3170 | 2930 | 2640 |
| 55.0 | | | | | | | | | | | | | 3100 | 2860 | 2580 |
| 56.0 | | | | | | | | | | | | | | 2790 | 2520 |
| 57.0 | | | | | | | | | | | | | | 2730 | 2460 |
| 57.5 | | | | | | | | | | | | | | 2700 | 2430 |
| 58.0 | | | | | | | | | | | | | | | 2410 |
| 59.0 | | | | | | | | | | | | | | | 2350 |
| 60.0 | | | | | | | | | | | | | | | 2300 |

3 Tower combinations

3 Tower combinations

| | |
|---|--|
|  | <p style="text-align: center;">! DANGER</p> <p>Usage of incorrect tower combinations. The slewing tower crane may overturn.</p> <ol style="list-style-type: none">1) Use the specified tower combinations.2) If you need another tower combination that is not specified here, please contact WOLFFKRAN to get an approved alternative setup in writing. |
|  | <p style="text-align: center;">NOTICE</p> <p>All tower combinations apply to free standing slewing tower cranes without climbing gear.</p> |
|  | <p style="text-align: center;">NOTICE</p> <p>The slewing tower crane with TFS 20 tower top lower part is without climbing feature.</p> |
|  | <p style="text-align: center;">NOTICE</p> <p>For tower combination with tower element TV 25 and UV 25 please contact WOLFFKRAN.</p> |

3.1 Tower combinations on foundation (slewing section with TFS 20 - connection)

| Jib length | 25 m – 60 m | | | |
|------------------------------|-------------|-------------------|-----------------------|-----------------------|
| Item | | | | |
| 1 | 4.5 m | TFS 20 | TFS 20 | TFS 20 |
| 2 | 9.0 m | TFS 20 | TFS 20 | TFS 20 |
| 3 | 13.5 m | TFS 20 | TFS 20.4 | TFS 20.4 |
| 4 | 18.0 m | TFS 20.4 | TFS 20.4 | TFS 20.4 |
| 5 | 22.5 m | TFS 20.4 | TFS 20.4 | TFS 20.4 |
| 6 | 27.0 m | TFS 20.4 | TFS 20.4 | TFS 20.4 |
| 7 | 31.5 m | TFS 20.4 | TFS 20.4 | TFS 20.4 |
| 8 | 36.0 m | TFS 20.4 | TFS 20.4 | TFS 20.4 |
| 9 | 40.5 m | TFS 20.4 | TFS 20.4 | UVA 20.4 |
| 10 | 45.0 m | | UVA 20.4 | UV 20.4 |
| 11 | 49.5 m | | UV 20.4 | UV 20.4 |
| 12 | 54.0 m | | UV 20.4 | TVA 20.4 |
| 13 | 58.5 m | | | TV 20.4 |
| 14 | 63.0 m | | | TV 20.4 |
| 15 | 67.5 m | | | TV 20.4 |
| Foundation anchors | | FUA B.4 FUA 93 | FUA 120 Type D-120 | FUA 140 Type D-140 |
| Tower height [m] | | 40.5 | 54.0 | 67.5 |
| Hook height above ground [m] | | 42.0 | 55.5 | 69.0 |
| Wind category | | C25 | | |

3 Tower combinations

| Jib length | 25 m – 60 m | | | |
|------------------------------|-------------|-----------------------|--|--|
| Item | | | | |
| 1 | 4.5 m | TFS 20 | | |
| 2 | 9.0 m | TFS 20 | | |
| 3 | 13.5 m | TFS 20.4 | | |
| 4 | 18.0 m | TFS 20.4 | | |
| 5 | 22.5 m | TFS 20.4 | | |
| 6 | 27.0 m | TFS 20.4 | | |
| 7 | 31.5 m | TFS 20.4 | | |
| 8 | 36.0 m | UVA 20.4 | | |
| 9 | 40.5 m | UV 20.4 | | |
| 10 | 45.0 m | UV 20.4 | | |
| 11 | 49.5 m | UV 20.4 | | |
| 12 | 54.0 m | TVA 20.4 | | |
| 13 | 58.5 m | TV 20.4 | | |
| 14 | 63.0 m | TV 20.4 | | |
| 15 | 67.5 m | TV 20.4 | | |
| 16 | 68.5 m | VR 2023 | | |
| 17 | 73.0 m | TV 23 | | |
| 18 | 77.5 m | TV 23 | | |
| | | | | |
| Foundation anchors | | FUA 140 Type D-140 | | |
| Tower height [m] | | 77.5 | | |
| Hook height above ground [m] | | 79.0 | | |
| Wind category | C25 | | | |

| Jib length | 25 m – 60 m | | | |
|------------------------------|-------------|-----------|-----|--|
| Item | | | | |
| 1 | 4.5 m | TFS 20 | | |
| 2 | 9.0 m | TFS 20 | | |
| 3 | 13.5 m | TFS 20.4 | | |
| 4 | 18.0 m | TFS 20.4 | | |
| 5 | 22.5 m | TFS 20.4 | | |
| 6 | 27.0 m | TFS 20.4 | | |
| 7 | 31.5 m | UVA 20.4 | | |
| 8 | 36.0 m | UV 20.4 | | |
| 9 | 40.5 m | UV 20.4 | | |
| 10 | 45.0 m | UV 20.4 | | |
| 11 | 49.5 m | TVA 20.4 | | |
| 12 | 54.0 m | TV 20.4 | | |
| 13 | 58.5 m | TV 20.4 | | |
| 14 | 63.0 m | TV 20.4 | | |
| 15 | 67.5 m | TV 20.4 | | |
| 16 | 68.5 m | VR 2023 | | |
| 17 | 73.0 m | TV 23 | | |
| 18 | 77.5 m | HTA 23 | | |
| 19 | 82.0 m | HT 23 | | |
| 20 | 86.5 m | HT 23 | | |
| 21 | 91.0 m | HT 23 | | |
| | | | | |
| Foundation anchors | | FUA G 160 | | |
| Tower height [m] | | 91.0 | | |
| Hook height above ground [m] | | 92.5 | | |
| Wind category | | | C25 | |

3 Tower combinations

| Jib length | | 25 m – 60 m | | | |
|------------------------------|--------|-------------|--|--|--|
| Item | | | | | |
| 1 | 4.5 m | TFS 20 | | | |
| 2 | 9.0 m | TFS 20 | | | |
| 3 | 13.5 m | TFS 20.4 | | | |
| 4 | 18.0 m | TFS 20.4 | | | |
| 5 | 22.5 m | TFS 20.4 | | | |
| 6 | 27.0 m | TFS 20.4 | | | |
| 7 | 31.5 m | UVA 20.4 | | | |
| 8 | 36.0 m | UV 20.4 | | | |
| 9 | 40.5 m | UV 20.4 | | | |
| 10 | 45.0 m | UV 20.4 | | | |
| 11 | 49.5 m | TVA 20.4 | | | |
| 12 | 54.0 m | TV 20.4 | | | |
| 13 | 58.5 m | TV 20.4 | | | |
| 14 | 63.0 m | TV 20.4 | | | |
| 15 | 64.0 m | VR 2023 | | | |
| 16 | 68.5 m | TV 23 | | | |
| 17 | 73.0 m | HTA 23 | | | |
| 18 | 77.5 m | HT 23 | | | |
| 19 | 82.0 m | HT 23 | | | |
| 20 | 86.5 m | HT 23 | | | |
| 21 | 97.8 m | BT 23 | | | |
| | | | | | |
| | | | | | |
| | | | | | |
| Foundation anchors | | FUA 210 G | | | |
| Tower height [m] | | 97.8 | | | |
| Hook height above ground [m] | | 99.3 | | | |
| Wind category | | C25 | | | |

| Jib length | 25 m – 60 m | | | |
|------------------------------|-------------|-------------|-----|--|
| Item | | | | |
| 1 | 4.5 m | TFS 20 | | |
| 2 | 9.0 m | TFS 20 | | |
| 3 | 13.5 m | TFS 20.4 | | |
| 4 | 18.0 m | TFS 20.4 | | |
| 5 | 22.5 m | TFS 20.4 | | |
| 6 | 27.0 m | TFS 20.4 | | |
| 7 | 31.5 m | UVA 20.4 | | |
| 8 | 36.0 m | UV 20.4 | | |
| 9 | 40.5 m | UV 20.4 | | |
| 10 | 45.0 m | UV 20.4 | | |
| 11 | 49.5 m | TVA 20.4 | | |
| 12 | 54.0 m | TV 20.4 | | |
| 13 | 58.5 m | TV 20.4 | | |
| 14 | 63.0 m | TV 20.4 | | |
| 15 | 64.0 m | VR 2023 | | |
| 16 | 68.5 m | TV 23 | | |
| 17 | 73.0 m | HTA 23 | | |
| 18 | 77.5 m | HT 23 | | |
| 19 | 82.0 m | HT 23 | | |
| 20 | 86.5 m | HT 23 | | |
| 21 | 87.7 m | VR 23/25-29 | | |
| 22 | 92.2 m | UV 29 | | |
| 23 | 102.2 m | BT 29 | | |
| | | | | |
| Foundation anchors | | FUA BT 29 | | |
| Tower height [m] | | 102.2 | | |
| Hook height above ground [m] | | 103.7 | | |
| Wind category | | | C25 | |

3 Tower combinations

3.2 Tower combinations on foundation (slewing section with UV 20 / TV 20 - connection)

| Jib length | | 25 m – 60 m | | | |
|------------------------------|--------|-----------------------|-----------------------|--|--|
| Item | | | | | |
| 1 | 4.5 m | UV 20.4 | UV 20.4 | | |
| 2 | 9.0 m | UV 20.4 | UV 20.4 | | |
| 3 | 13.5 m | UV 20.4 | UV 20.4 | | |
| 4 | 18.0 m | UV 20.4 | UV 20.4 | | |
| 5 | 22.5 m | UV 20.4 | UV 20.4 | | |
| 6 | 27.0 m | UV 20.4 | UV 20.4 | | |
| 7 | 31.5 m | UV 20.4 | UV 20.4 | | |
| 8 | 36.0 m | UV 20.4 | UV 20.4 | | |
| 9 | 40.5 m | UV 20.4 | UV 20.4 | | |
| 10 | 45.0 m | UV 20.4 | UV 20.4 | | |
| 11 | 49.5 m | UV 20.4 | UV 20.4 | | |
| 12 | 54.0 m | UV 20.4 | TVA 20.4 | | |
| 13 | 58.5 m | | TV 20.4 | | |
| 14 | 63.0 m | | TV 20.4 | | |
| 15 | 67.5 m | | TV 20.4 | | |
| | | | | | |
| Foundation anchors | | FUA 120 Type C-120 | FUA 140 Type D-140 | | |
| Tower height [m] | | 54.0 | 67.5 | | |
| Hook height above ground [m] | | 55.5 | 69.0 | | |
| Wind category | | C25 | | | |

| Jib length | 25 m – 60 m | | | |
|------------------------------|-------------|-----------------------|-----------|--|
| Item | | | | |
| 1 | 4.5 m | UV 20.4 | UV 20.4 | |
| 2 | 9.0 m | UV 20.4 | UV 20.4 | |
| 3 | 13.5 m | UV 20.4 | UV 20.4 | |
| 4 | 18.0 m | UV 20.4 | UV 20.4 | |
| 5 | 22.5 m | UV 20.4 | UV 20.4 | |
| 6 | 27.0 m | UV 20.4 | UV 20.4 | |
| 7 | 31.5 m | UV 20.4 | UV 20.4 | |
| 8 | 36.0 m | UV 20.4 | UV 20.4 | |
| 9 | 40.5 m | UV 20.4 | UV 20.4 | |
| 10 | 45.0 m | UV 20.4 | UV 20.4 | |
| 11 | 49.5 m | UV 20.4 | TVA 20.4 | |
| 12 | 54.0 m | TVA 20.4 | TV 20.4 | |
| 13 | 58.5 m | TV 20.4 | TV 20.4 | |
| 14 | 63.0 m | TV 20.4 | TV 20.4 | |
| 15 | 67.5 m | TV 20.4 | TV 20.4 | |
| 16 | 68.5 m | VR 2023 | VR 2023 | |
| 17 | 73.0 m | TV 23 | TV 23 | |
| 18 | 77.5 m | TV 23 | HTA 23 | |
| 19 | 82.0 m | | HT 23 | |
| 20 | 86.5 m | | HT 23 | |
| | | | | |
| Foundation anchors | | FUA 140 Type D-140 | FUA G 160 | |
| Tower height [m] | | 77.5 | 86.5 | |
| Hook height above ground [m] | | 79.0 | 88.0 | |
| Wind category | C25 | | | |

3 Tower combinations

| Jib length | 25 m – 60 m | | | |
|------------------------------|-------------|-----------|-----|--|
| Item | | | | |
| 1 | 4.5 m | UV 20.4 | | |
| 2 | 9.0 m | UV 20.4 | | |
| 3 | 13.5 m | UV 20.4 | | |
| 4 | 18.0 m | UV 20.4 | | |
| 5 | 22.5 m | UV 20.4 | | |
| 6 | 27.0 m | UV 20.4 | | |
| 7 | 31.5 m | UV 20.4 | | |
| 8 | 36.0 m | UV 20.4 | | |
| 9 | 40.5 m | UV 20.4 | | |
| 10 | 45.0 m | UV 20.4 | | |
| 11 | 49.5 m | TVA 20.4 | | |
| 12 | 54.0 m | TV 20.4 | | |
| 13 | 58.5 m | TV 20.4 | | |
| 14 | 63.0 m | TV 20.4 | | |
| 15 | 64.0 m | VR 2023 | | |
| 16 | 68.5 m | TV 23 | | |
| 17 | 73.0 m | HTA 23 | | |
| 18 | 77.5 m | HT 23 | | |
| 19 | 82.0 m | HT 23 | | |
| 20 | 93.3 m | BT 23 | | |
| | | | | |
| Foundation anchors | | FUA 210 G | | |
| Tower height [m] | | 93.3 | | |
| Hook height above ground [m] | | 94.8 | | |
| Wind category | | | C25 | |

| Jib length | 25 m – 60 m | | | |
|------------------------------|-------------|-------------|-----|--|
| Item | | | | |
| 1 | 4.5 m | UV 20.4 | | |
| 2 | 9.0 m | UV 20.4 | | |
| 3 | 13.5 m | UV 20.4 | | |
| 4 | 18.0 m | UV 20.4 | | |
| 5 | 22.5 m | UV 20.4 | | |
| 6 | 27.0 m | UV 20.4 | | |
| 7 | 31.5 m | UV 20.4 | | |
| 8 | 36.0 m | UV 20.4 | | |
| 9 | 40.5 m | UV 20.4 | | |
| 10 | 45.0 m | UV 20.4 | | |
| 11 | 49.5 m | TVA 20.4 | | |
| 12 | 54.0 m | TV 20.4 | | |
| 13 | 58.5 m | TV 20.4 | | |
| 14 | 63.0 m | TV 20.4 | | |
| 15 | 64.0 m | VR 2023 | | |
| 16 | 68.5 m | TV 23 | | |
| 17 | 73.0 m | HTA 23 | | |
| 18 | 77.5 m | HT 23 | | |
| 19 | 82.0 m | HT 23 | | |
| 20 | 83.2 m | VR 23/25-29 | | |
| 21 | 87.7 m | UV 29 | | |
| 22 | 92.2 m | UV 29 | | |
| 23 | 102.2 m | BT 29 | | |
| | | | | |
| Foundation anchors | | FUA BT 29 | | |
| Tower height [m] | | 102.2 | | |
| Hook height above ground [m] | | 103.7 | | |
| Wind category | | | C25 | |

3 Tower combinations

3.3 Tower combinations on cross frame (slewing section with TFS 20 - connection)

| Jib length | 25 m – 60 m | | | | |
|------------------------------|-------------|------------------------|------------------------|-------------------------|------------------------|
| Item | | | | | |
| 1 | 4.5 m | TFS 20 | TFS 20 | TFS 20 | TFS 20 |
| 2 | 9.0 m | TFS 20 | TFS 20 | TFS 20 | TFS 20 |
| 3 | 13.5 m | TFS 20 | TFS 20 | TFS 20.4 | TFS 20.4 |
| 4 | 18.0 m | TFS 20.4 | TFS 20.4 | TFS 20.4 | TFS 20.4 |
| 5 | 22.5 m | TFS 20.4 | TFS 20.4 | TFS 20.4 | TFS 20.4 |
| 6 | 27.0 m | TFS 20.4 | TFS 20.4 | TFS 20.4 | TFS 20.4 |
| 7 | 31.5 m | | TFS 20.4 | TFS 20.4 | TFS 20.4 |
| 8 | 36.0 m | | TFS 20.4 | TFS 20.4 | TFS 20.4 |
| 9 | 40.5 m | | | UVA 20.4 | UVA 20.4 |
| 10 | 45.0 m | | | UV 20.4 | UV 20.4 |
| 11 | 49.5 m | | | UV 20.4 | UV 20.4 |
| 12 | 54.0 m | | | TVA 20.4 | TVA 20.4 |
| 13 | 58.5 m | | | TV 20.4 | TV 20.4 |
| 14 | 63.0 m | | | TV 20.4 | TV 20.4 |
| 15 | 67.5 m | | | | TV 20.4 |
| 16 | 72.0 m | | | | |
| Substructure | | KR 800-5 KR 800-6 | KRV 7-32/46 KR 8-46 | KR 10-46 KR 10-46/60 | KRV 10-60 |
| Corner distance [m x m] | | 5.0 x 5.0 6.0 x 6.0 | 4.6 x 4.6 | 4.6 x 4.6 6.0 x 6.0 | 5.0 x 5.0 6.0 x 6.0 |
| Substructure height [m] | | 0.9 | 0.9 | 1.2 | 1.2 |
| Tower height [m] | | 27.9 | 36.9 | 64.2 | 68.7 |
| Hook height above ground [m] | | 29.4 | 38.4 | 65.7 | 70.2 |
| Wind category | | C25 | | | |

| Jib length | 25 m – 60 m | | | |
|------------------------------|-------------|-----------|-----------|--|
| Item | | | | |
| 1 | 4.5 m | TFS 20 | TFS 20 | |
| 2 | 9.0 m | TFS 20 | TFS 20 | |
| 3 | 13.5 m | TFS 20.4 | TFS 20.4 | |
| 4 | 18.0 m | TFS 20.4 | TFS 20.4 | |
| 5 | 22.5 m | TFS 20.4 | TFS 20.4 | |
| 6 | 27.0 m | TFS 20.4 | TFS 20.4 | |
| 7 | 31.5 m | TFS 20.4 | TFS 20.4 | |
| 8 | 36.0 m | UVA 20.4 | UVA 20.4 | |
| 9 | 40.5 m | UV 20.4 | UV 20.4 | |
| 10 | 45.0 m | UV 20.4 | UV 20.4 | |
| 11 | 49.5 m | UV 20.4 | UV 20.4 | |
| 12 | 54.0 m | TVA 20.4 | TVA 20.4 | |
| 13 | 58.5 m | TV 20.4 | TV 20.4 | |
| 14 | 63.0 m | TV 20.4 | TV 20.4 | |
| 15 | 67.5 m | TV 20.4 | TV 20.4 | |
| 16 | 68.5 m | VR 2023 | VR 2023 | |
| 17 | 73.0 m | TV 23 | TV 23 | |
| 18 | 77.5 m | | TV 23 | |
| | | | | |
| Substructure | | KRV 10-60 | KRV 10-60 | |
| Corner distance [m x m] | | 5.0 x 5.0 | 6.0 x 6.0 | |
| Substructure height [m] | | 1.2 | 1.2 | |
| Tower height [m] | | 74.2 | 78.7 | |
| Hook height above ground [m] | | 75.7 | 80.2 | |
| Wind category | | C25 | | |

3 Tower combinations

| Jib length | 25 m – 60 m | | | |
|------------------------------|-------------|-----------|-------------------------|--|
| Item | | | | |
| 1 | 4.5 m | TFS 20 | TFS 20 | |
| 2 | 9.0 m | TFS 20 | TFS 20 | |
| 3 | 13.5 m | TFS 20.4 | TFS 20.4 | |
| 4 | 18.0 m | TFS 20.4 | TFS 20.4 | |
| 5 | 22.5 m | TFS 20.4 | TFS 20.4 | |
| 6 | 27.0 m | TFS 20.4 | TFS 20.4 | |
| 7 | 31.5 m | TFS 20.4 | TFS 20.4 | |
| 8 | 36.0 m | TFS 20.4 | TFS 20.4 | |
| 9 | 40.5 m | UVA 20.4 | UVA 20.4 | |
| 10 | 45.0 m | UV 20.4 | UV 20.4 | |
| 11 | 49.5 m | TVA 20.4 | UV 20.4 | |
| 12 | 54.0 m | TV 20.4 | TVA 20.4 | |
| 13 | 58.5 m | TV 20.4 | TV 20.4 | |
| 14 | 63.0 m | TV 20.4 | TV 20.4 | |
| 15 | 67.5 m | TVÜ 20.4 | TV 20.4 | |
| | | TV 25 | | |
| Substructure | | KR 1000-8 | KR 12-60 KR 12-60/80 | |
| Corner distance [m x m] | | 8.0 x 8.0 | 6.0 x 6.0 8.0 x 8.0 | |
| Substructure height [m] | | 1.2 | 1.4 | |
| Tower height [m] | | 73.2 | 68.9 | |
| Hook height above ground [m] | | 74.7 | 70.4 | |
| Wind category | C25 | | | |

| Jib length | 25 m – 60 m | | | |
|------------------------------|-------------|-----------|-------------|--------------------------|
| Item | | | | |
| 1 | 4.5 m | TFS 20 | TFS 20 | TFS 20 |
| 2 | 9.0 m | TFS 20 | TFS 20 | TFS 20 |
| 3 | 13.5 m | TFS 20.4 | TFS 20.4 | TFS 20.4 |
| 4 | 18.0 m | TFS 20.4 | TFS 20.4 | TFS 20.4 |
| 5 | 22.5 m | TFS 20.4 | TFS 20.4 | TFS 20.4 |
| 6 | 27.0 m | TFS 20.4 | TFS 20.4 | TFS 20.4 |
| 7 | 31.5 m | TFS 20.4 | TFS 20.4 | TFS 20.4 |
| 8 | 36.0 m | UVA 20.4 | UVA 20.4 | UVA 20.4 |
| 9 | 40.5 m | UV 20.4 | UV 20.4 | UV 20.4 |
| 10 | 45.0 m | UV 20.4 | UV 20.4 | UV 20.4 |
| 11 | 49.5 m | UV 20.4 | TVA 20.4 | TVA 20.4 |
| 12 | 54.0 m | TVA 20.4 | TV 20.4 | TV 20.4 |
| 13 | 58.5 m | TV 20.4 | TV 20.4 | TV 20.4 |
| 14 | 63.0 m | TV 20.4 | TV 20.4 | TV 20.4 |
| 15 | 67.5 m | TV 20.4 | TV 20.4 | TV 20.4 |
| 16 | 68.5 m | VR 2023 | VR 2023 | VR 2023 |
| 17 | 73.0 m | TV 23 | TV 23 | TV 23 |
| 18 | 77.5 m | HTA 23 | HTA 23 | HTA 23 |
| 19 | 82.0 m | HT 23 | HT 23 | HT 23 |
| 20 | 86.5 m | | HT 23 | HT 23 |
| | | | | |
| Substructure | | KR 12-60 | KR 12-60/80 | KR 16-80 KR 16-80/100 |
| Corner distance [m x m] | | 6.0 x 6.0 | 8.0 x 8.0 | 8.0 x 8.0 10.0 x 10.0 |
| Substructure height [m] | | 1.4 | 1.4 | 1.8 |
| Tower height [m] | | 83.4 | 87.9 | 88.3 |
| Hook height above ground [m] | | 84.9 | 89.4 | 89.8 |
| Wind category | | C25 | | |

3 Tower combinations

| Jib length | 25 m – 60 m | | | | |
|------------------------------|-------------|-------------|--|--|--|
| Item | | | | | |
| 1 | 4.5 m | TFS 20 | | | |
| 2 | 9.0 m | TFS 20 | | | |
| 3 | 13.5 m | TFS 20.4 | | | |
| 4 | 18.0 m | TFS 20.4 | | | |
| 5 | 22.5 m | TFS 20.4 | | | |
| 6 | 27.0 m | TFS 20.4 | | | |
| 7 | 31.5 m | UVA 20.4 | | | |
| 8 | 36.0 m | UV 20.4 | | | |
| 9 | 40.5 m | UV 20.4 | | | |
| 10 | 45.0 m | UV 20.4 | | | |
| 11 | 49.5 m | TVA 20.4 | | | |
| 12 | 54.0 m | TV 20.4 | | | |
| 13 | 58.5 m | TV 20.4 | | | |
| 14 | 63.0 m | TV 20.4 | | | |
| 15 | 64.0 m | VR 2023 | | | |
| 16 | 68.5 m | TV 23 | | | |
| 17 | 73.0 m | HTA 23 | | | |
| 18 | 77.5 m | HT 23 | | | |
| 19 | 82.0 m | HT 23 | | | |
| 20 | 86.5 m | HT 23 | | | |
| 21 | 87.7 m | VR 23/25-29 | | | |
| 22 | 97.7 m | BT 29 | | | |
| | | | | | |
| | | | | | |
| Substructure | | KR 16-80 | | | |
| Corner distance [m x m] | | 8.0 x 8.0 | | | |
| Substructure height [m] | | 1.8 | | | |
| Tower height [m] | | 99.5 | | | |
| Hook height above ground [m] | | 101.0 | | | |
| Wind category | | C25 | | | |

| Jib length | 25 m – 60 m | | | |
|------------------------------|-------------|--------------|-----|--|
| Item | | | | |
| 1 | 4.5 m | TFS 20 | | |
| 2 | 9.0 m | TFS 20 | | |
| 3 | 13.5 m | TFS 20.4 | | |
| 4 | 18.0 m | TFS 20.4 | | |
| 5 | 22.5 m | TFS 20.4 | | |
| 6 | 27.0 m | TFS 20.4 | | |
| 7 | 31.5 m | UVA 20.4 | | |
| 8 | 36.0 m | UV 20.4 | | |
| 9 | 40.5 m | UV 20.4 | | |
| 10 | 45.0 m | UV 20.4 | | |
| 11 | 49.5 m | TVA 20.4 | | |
| 12 | 54.0 m | TV 20.4 | | |
| 13 | 58.5 m | TV 20.4 | | |
| 14 | 63.0 m | TV 20.4 | | |
| 15 | 64.0 m | VR 2023 | | |
| 16 | 68.5 m | TV 23 | | |
| 17 | 73.0 m | HTA 23 | | |
| 18 | 77.5 m | HT 23 | | |
| 19 | 82.0 m | HT 23 | | |
| 20 | 86.5 m | HT 23 | | |
| 21 | 87.7 m | VR 23/25-29 | | |
| 22 | 92.2 m | UV 29 | | |
| 23 | 102.2 m | BT 29 | | |
| | | | | |
| | | | | |
| | | | | |
| Substructure | | KR 16-80/100 | | |
| Corner distance [m x m] | | 10.0 x 10.0 | | |
| Substructure height [m] | | 1.8 | | |
| Tower height [m] | | 104.0 | | |
| Hook height above ground [m] | | 105.5 | | |
| Wind category | | | C25 | |

3 Tower combinations

3.4 Tower combinations on cross frame (slewing section with UV 20 / TV 20 - connection)

| Jib length | 25 m – 60 m | | | | |
|------------------------------|-------------|------------------------|------------------------|-------------------------|------------------------|
| Item | | | | | |
| 1 | 4.5 m | UV 20.4 | UV 20.4 | UV 20.4 | UV 20.4 |
| 2 | 9.0 m | UV 20.4 | UV 20.4 | UV 20.4 | UV 20.4 |
| 3 | 13.5 m | UV 20.4 | UV 20.4 | UV 20.4 | UV 20.4 |
| 4 | 18.0 m | UV 20.4 | UV 20.4 | UV 20.4 | UV 20.4 |
| 5 | 22.5 m | UV 20.4 | UV 20.4 | UV 20.4 | UV 20.4 |
| 6 | 27.0 m | UV 20.4 | UV 20.4 | UV 20.4 | UV 20.4 |
| 7 | 31.5 m | | UV 20.4 | UV 20.4 | UV 20.4 |
| 8 | 36.0 m | | UV 20.4 | UV 20.4 | UV 20.4 |
| 9 | 40.5 m | | | UV 20.4 | UV 20.4 |
| 10 | 45.0 m | | | UV 20.4 | UV 20.4 |
| 11 | 49.5 m | | | UV 20.4 | UV 20.4 |
| 12 | 54.0 m | | | TVA 20.4 | TVA 20.4 |
| 13 | 58.5 m | | | TV 20.4 | TV 20.4 |
| 14 | 63.0 m | | | TV 20.4 | TV 20.4 |
| 15 | 67.5 m | | | | TV 20.4 |
| 16 | 72.0 m | | | | |
| Substructure | | KR 800-5 KR 800-6 | KRV 7-32/46 KR 8-46 | KR 10-46 KR 10-46/60 | KRV 10-60 |
| Corner distance [m x m] | | 5.0 x 5.0 6.0 x 6.0 | 4.6 x 4.6 | 4.6 x 4.6 6.0 x 6.0 | 5.0 x 5.0 6.0 x 6.0 |
| Substructure height [m] | | 0.9 | 0.9 | 1.2 | 1.2 |
| Tower height [m] | | 27.9 | 36.9 | 64.2 | 68.7 |
| Hook height above ground [m] | | 29.4 | 38.4 | 65.7 | 70.2 |
| Wind category | | C25 | | | |

| Jib length | 25 m – 60 m | | | |
|------------------------------|-------------|-----------|-----------|--|
| Item | | | | |
| 1 | 4.5 m | UV 20.4 | UV 20.4 | |
| 2 | 9.0 m | UV 20.4 | UV 20.4 | |
| 3 | 13.5 m | UV 20.4 | UV 20.4 | |
| 4 | 18.0 m | UV 20.4 | UV 20.4 | |
| 5 | 22.5 m | UV 20.4 | UV 20.4 | |
| 6 | 27.0 m | UV 20.4 | UV 20.4 | |
| 7 | 31.5 m | UV 20.4 | UV 20.4 | |
| 8 | 36.0 m | UV 20.4 | UV 20.4 | |
| 9 | 40.5 m | UV 20.4 | UV 20.4 | |
| 10 | 45.0 m | UV 20.4 | UV 20.4 | |
| 11 | 49.5 m | UV 20.4 | UV 20.4 | |
| 12 | 54.0 m | TVA 20.4 | TVA 20.4 | |
| 13 | 58.5 m | TV 20.4 | TV 20.4 | |
| 14 | 63.0 m | TV 20.4 | TV 20.4 | |
| 15 | 67.5 m | TV 20.4 | TV 20.4 | |
| 16 | 68.5 m | VR 2023 | VR 2023 | |
| 17 | 73.0 m | TV 23 | TV 23 | |
| 18 | 77.5 m | | TV 23 | |
| | | | | |
| Substructure | | KRV 10-60 | KRV 10-60 | |
| Corner distance [m x m] | | 5.0 x 5.0 | 6.0 x 6.0 | |
| Substructure height [m] | | 1.2 | 1.2 | |
| Tower height [m] | | 74.2 | 78.7 | |
| Hook height above ground [m] | | 75.7 | 80.2 | |
| Wind category | | C25 | | |

3 Tower combinations

| Jib length | 25 m – 60 m | | | |
|------------------------------|-------------|-----------|-------------------------|--|
| Item | | | | |
| 1 | 4.5 m | UV 20.4 | UV 20.4 | |
| 2 | 9.0 m | UV 20.4 | UV 20.4 | |
| 3 | 13.5 m | UV 20.4 | UV 20.4 | |
| 4 | 18.0 m | UV 20.4 | UV 20.4 | |
| 5 | 22.5 m | UV 20.4 | UV 20.4 | |
| 6 | 27.0 m | UV 20.4 | UV 20.4 | |
| 7 | 31.5 m | UV 20.4 | UV 20.4 | |
| 8 | 36.0 m | UV 20.4 | UV 20.4 | |
| 9 | 40.5 m | UV 20.4 | UV 20.4 | |
| 10 | 45.0 m | UV 20.4 | UV 20.4 | |
| 11 | 49.5 m | TVA 20.4 | UV 20.4 | |
| 12 | 54.0 m | TV 20.4 | TVA 20.4 | |
| 13 | 58.5 m | TV 20.4 | TV 20.4 | |
| 14 | 63.0 m | TV 20.4 | TV 20.4 | |
| 15 | 67.5 m | TVÜ 20.4 | TV 20.4 | |
| | | TV 25 | | |
| Substructure | | KR 1000-8 | KR 12-60 KR 12-60/80 | |
| Corner distance [m x m] | | 8.0 x 8.0 | 6.0 x 6.0 8.0 x 8.0 | |
| Substructure height [m] | | 1.2 | 1.4 | |
| Tower height [m] | | 73.2 | 68.9 | |
| Hook height above ground [m] | | 74.7 | 70.4 | |
| Wind category | | C25 | | |

| Jib length | 25 m – 60 m | | | | |
|------------------------------|-------------|-----------|-------------|--------------------------|--|
| Item | | | | | |
| 1 | 4.5 m | UV 20.4 | UV 20.4 | UV 20.4 | |
| 2 | 9.0 m | UV 20.4 | UV 20.4 | UV 20.4 | |
| 3 | 13.5 m | UV 20.4 | UV 20.4 | UV 20.4 | |
| 4 | 18.0 m | UV 20.4 | UV 20.4 | UV 20.4 | |
| 5 | 22.5 m | UV 20.4 | UV 20.4 | UV 20.4 | |
| 6 | 27.0 m | UV 20.4 | UV 20.4 | UV 20.4 | |
| 7 | 31.5 m | UV 20.4 | UV 20.4 | UV 20.4 | |
| 8 | 36.0 m | UV 20.4 | UV 20.4 | UV 20.4 | |
| 9 | 40.5 m | UV 20.4 | UV 20.4 | UV 20.4 | |
| 10 | 45.0 m | UV 20.4 | UV 20.4 | UV 20.4 | |
| 11 | 49.5 m | UV 20.4 | TVA 20.4 | TVA 20.4 | |
| 12 | 54.0 m | TVA 20.4 | TV 20.4 | TV 20.4 | |
| 13 | 58.5 m | TV 20.4 | TV 20.4 | TV 20.4 | |
| 14 | 63.0 m | TV 20.4 | TV 20.4 | TV 20.4 | |
| 15 | 67.5 m | TV 20.4 | TV 20.4 | TV 20.4 | |
| 16 | 68.5 m | VR 2023 | VR 2023 | VR 2023 | |
| 17 | 73.0 m | TV 23 | TV 23 | TV 23 | |
| 18 | 77.5 m | HTA 23 | HTA 23 | HTA 23 | |
| 19 | 82.0 m | HT 23 | HT 23 | HT 23 | |
| 20 | 86.5 m | | HT 23 | HT 23 | |
| | | | | | |
| Substructure | | KR 12-60 | KR 12-60/80 | KR 16-80 KR 16-80/100 | |
| Corner distance [m x m] | | 6.0 x 6.0 | 8.0 x 8.0 | 8.0 x 8.0 10.0 x 10.0 | |
| Substructure height [m] | | 1.4 | 1.4 | 1.8 | |
| Tower height [m] | | 83.4 | 87.9 | 88.3 | |
| Hook height above ground [m] | | 84.9 | 89.4 | 89.8 | |
| Wind category | | C25 | | | |

| Jib length | | 25 m – 60 m | | |
|------------------------------|---------|--------------|-----|--|
| Item | | | | |
| 1 | 4.5 m | UV 20.4 | | |
| 2 | 9.0 m | UV 20.4 | | |
| 3 | 13.5 m | UV 20.4 | | |
| 4 | 18.0 m | UV 20.4 | | |
| 5 | 22.5 m | UV 20.4 | | |
| 6 | 27.0 m | UV 20.4 | | |
| 7 | 31.5 m | UV 20.4 | | |
| 8 | 36.0 m | UV 20.4 | | |
| 9 | 40.5 m | UV 20.4 | | |
| 10 | 45.0 m | UV 20.4 | | |
| 11 | 49.5 m | TVA 20.4 | | |
| 12 | 54.0 m | TV 20.4 | | |
| 13 | 58.5 m | TV 20.4 | | |
| 14 | 63.0 m | TV 20.4 | | |
| 15 | 64.0 m | VR 2023 | | |
| 16 | 68.5 m | TV 23 | | |
| 17 | 73.0 m | HTA 23 | | |
| 18 | 77.5 m | HT 23 | | |
| 19 | 82.0 m | HT 23 | | |
| 20 | 83.2 m | VR 23/25-29 | | |
| 21 | 87.7 m | UV 29 | | |
| 22 | 92.2 m | UV 29 | | |
| 23 | 102.2 m | BT 29 | | |
| | | | | |
| | | | | |
| Substructure | | KR 16-80/100 | | |
| Corner distance [m x m] | | 10.0 x 10.0 | | |
| Substructure height [m] | | 1.8 | | |
| Tower height [m] | | 104.0 | | |
| Hook height above ground [m] | | 105.5 | | |
| Wind category | | | C25 | |

3 Tower combinations

3.5 Tower combinations on cross frame element (slewing section with TFS 20 - connection)

| Jib length | | 25 m – 60 m | | | |
|------------------------------|--------|-------------|-----------|------------|-----------|
| Item | | | | | |
| 1 | 4.5 m | TFS 20 | TFS 20 | TFS 20 | TFS 20 |
| 2 | 9.0 m | TFS 20 | TFS 20 | TFS 20 | TFS 20 |
| 3 | 13.5 m | TFS 20 | TFS 20 | TFS 20.4 | TFS 20.4 |
| 4 | 18.0 m | TFS 20.4 | TFS 20.4 | TFS 20.4 | TFS 20.4 |
| 5 | 22.5 m | TFS 20.4 | TFS 20.4 | TFS 20.4 | TFS 20.4 |
| 6 | 27.0 m | TFS 20.4 | TFS 20.4 | TFS 20.4 | TFS 20.4 |
| 7 | 31.5 m | TFS 20.4 | TFS 20.4 | TFS 20.4 | TFS 20.4 |
| 8 | 36.0 m | UVA 20.4 | TFS 20.4 | TFS 20.4 | TFS 20.4 |
| 9 | 40.5 m | | UVA 20.4 | UVA 20.4 | UVA 20.4 |
| 10 | 45.0 m | | | UV 20.4 | UV 20.4 |
| 11 | 49.5 m | | | TVA 20.4 | UV 20.4 |
| 12 | 54.0 m | | | | TVA 20.4 |
| Substructure | | KRE 260.1 | KRE 260.1 | KRE 260.2 | KRE 260.2 |
| Corner distance [m x m] | | 5.0 x 6.79 | 6.0 x 6.0 | 5.0 x 6.79 | 6.0 x 6.0 |
| Substructure height [m] | | 4.0 | 4.0 | 4.0 | 4.0 |
| Tower height [m] | | 40.0 | 44.5 | 53.5 | 58.0 |
| Hook height above ground [m] | | 41.5 | 46.0 | 55.0 | 59.5 |
| Wind category | | C25 | | | |

| Jib length | 25 m – 60 m | | | |
|------------------------------|-------------|-----------|--|--|
| Item | | | | |
| 1 | 4.5 m | TFS 20 | | |
| 2 | 9.0 m | TFS 20 | | |
| 3 | 13.5 m | TFS 20.4 | | |
| 4 | 18.0 m | TFS 20.4 | | |
| 5 | 22.5 m | TFS 20.4 | | |
| 6 | 27.0 m | TFS 20.4 | | |
| 7 | 31.5 m | TFS 20.4 | | |
| 8 | 36.0 m | TFS 20.4 | | |
| 9 | 40.5 m | UVA 20.4 | | |
| 10 | 45.0 m | UV 20.4 | | |
| 11 | 49.5 m | TVA 20.4 | | |
| 12 | 54.0 m | TV 20.4 | | |
| 13 | 58.5 m | TV 20.4 | | |
| 14 | 63.0 m | TV 20.4 | | |
| 15 | 67.5 m | TVÜ 20.4 | | |
| 16 | 72.0 m | UVA 25 | | |
| Substructure | | KRE 480 | | |
| Corner distance [m x m] | | 8.0 x 8.0 | | |
| Substructure height [m] | | 4.0 | | |
| Tower height [m] | | 76.0 | | |
| Hook height above ground [m] | | 77.5 | | |
| Wind category | | C25 | | |

3 Tower combinations

3.6 Tower combinations on cross frame element (slewing section with UV 20 / TV 20 - connection)

| Jib length | 25 m – 60 m | | | | |
|------------------------------|-------------|------------|-----------|------------|-----------|
| Item | | | | | |
| 1 | 4.5 m | UV 20.4 | UV 20.4 | UV 20.4 | UV 20.4 |
| 2 | 9.0 m | UV 20.4 | UV 20.4 | UV 20.4 | UV 20.4 |
| 3 | 13.5 m | UV 20.4 | UV 20.4 | UV 20.4 | UV 20.4 |
| 4 | 18.0 m | UV 20.4 | UV 20.4 | UV 20.4 | UV 20.4 |
| 5 | 22.5 m | UV 20.4 | UV 20.4 | UV 20.4 | UV 20.4 |
| 6 | 27.0 m | UV 20.4 | UV 20.4 | UV 20.4 | UV 20.4 |
| 7 | 31.5 m | UV 20.4 | UV 20.4 | UV 20.4 | UV 20.4 |
| 8 | 36.0 m | UV 20.4 | UV 20.4 | UV 20.4 | UV 20.4 |
| 9 | 40.5 m | | UV 20.4 | UV 20.4 | UV 20.4 |
| 10 | 45.0 m | | | UV 20.4 | UV 20.4 |
| 11 | 49.5 m | | | TVA 20.4 | UV 20.4 |
| 12 | 54.0 m | | | | TVA 20.4 |
| Substructure | | KRE 260.1 | KRE 260.1 | KRE 260.2 | KRE 260.2 |
| Corner distance [m x m] | | 5.0 x 6.79 | 6.0 x 6.0 | 5.0 x 6.79 | 6.0 x 6.0 |
| Substructure height [m] | | 4.0 | 4.0 | 4.0 | 4.0 |
| Tower height [m] | | 40.0 | 44.5 | 53.5 | 58.0 |
| Hook height above ground [m] | | 41.5 | 46.0 | 55.0 | 59.5 |
| Wind category | | C25 | | | |

| Jib length | 25 m – 60 m | | | |
|------------------------------|-------------|-----------|-----|--|
| Item | | | | |
| 1 | 4.5 m | UV 20.4 | | |
| 2 | 9.0 m | UV 20.4 | | |
| 3 | 13.5 m | UV 20.4 | | |
| 4 | 18.0 m | UV 20.4 | | |
| 5 | 22.5 m | UV 20.4 | | |
| 6 | 27.0 m | UV 20.4 | | |
| 7 | 31.5 m | UV 20.4 | | |
| 8 | 36.0 m | UV 20.4 | | |
| 9 | 40.5 m | UV 20.4 | | |
| 10 | 45.0 m | UV 20.4 | | |
| 11 | 49.5 m | TVA 20.4 | | |
| 12 | 54.0 m | TV 20.4 | | |
| 13 | 58.5 m | TV 20.4 | | |
| 14 | 63.0 m | TV 20.4 | | |
| 15 | 67.5 m | TVÜ 20.4 | | |
| 16 | 72.0 m | UVA 25 | | |
| | | | | |
| | | | | |
| Substructure | | KRE 480 | | |
| Corner distance [m x m] | | 8.0 x 8.0 | | |
| Substructure height [m] | | 4.0 | | |
| Tower height [m] | | 76.0 | | |
| Hook height above ground [m] | | 77.5 | | |
| Wind category | | | C25 | |

3 Tower combinations

3.7 Tower combinations on mobile cross frame (slewing section with TFS 20 - connection)

| Jib length | 25 m – 60 m | | | |
|------------------------------|-------------|--------------|---------------|---------------|
| Item | | | | |
| 1 | 4.5 m | TFS 20 | TFS 20 | TFS 20 |
| 2 | 9.0 m | TFS 20 | TFS 20.4 | TFS 20.4 |
| 3 | 13.5 m | TFS 20.4 | TFS 20.4 | TFS 20.4 |
| 4 | 18.0 m | TFS 20.4 | TFS 20.4 | TFS 20.4 |
| 5 | 22.5 m | TFS 20.4 | TFS 20.4 | TFS 20.4 |
| 6 | 27.0 m | TFS 20.4 | TFS 20.4 | TFS 20.4 |
| 7 | 31.5 m | TFS 20.4 | UVA 20.4 | UVA 20.4 |
| 8 | 36.0 m | UVA 20.4 | UV 20.4 | UV 20.4 |
| 9 | 40.5 m | UV 20.4 | UV 20.4 | UV 20.4 |
| 10 | 45.0 m | UV 20.4 | UV 20.4 | UV 20.4 |
| 11 | 49.5 m | UV 20.4 | UV 20.4 | UV 20.4 |
| 12 | 54.0 m | TVA 20.4 | TVA 20.4 | TVA 20.4 |
| 13 | 58.5 m | TV 20.4 | TV 20.4 | TV 20.4 |
| 14 | 63.0 m | | TV 20.4 | TV 20.4 |
| 15 | 67.5 m | | TV 20.4 | TV 20.4 |
| Substructure | | KRF 10-46/60 | KRF4 12-60/80 | KRF6 12-60/80 |
| Corner distance [m x m] | | 6.0 x 6.0 | 8.0 x 8.0 | 8.0 x 8.0 |
| Substructure height [m] | | 2.0 | 2.5 | 2.9 |
| Tower height [m] | | 60.5 | 70.0 | 70.4 |
| Hook height above ground [m] | | 62.0 | 71.5 | 71.9 |
| Wind category | | C25 | | |

| Jib length | 25 m – 60 m | | | |
|------------------------------|-------------|---------------|---------------|--|
| Item | | | | |
| 1 | 4.5 m | TFS 20 | TFS 20 | |
| 2 | 9.0 m | TFS 20.4 | TFS 20.4 | |
| 3 | 13.5 m | TFS 20.4 | TFS 20.4 | |
| 4 | 18.0 m | TFS 20.4 | TFS 20.4 | |
| 5 | 22.5 m | TFS 20.4 | TFS 20.4 | |
| 6 | 27.0 m | TFS 20.4 | TFS 20.4 | |
| 7 | 31.5 m | UVA 20.4 | UVA 20.4 | |
| 8 | 36.0 m | UV 20.4 | UV 20.4 | |
| 9 | 40.5 m | UV 20.4 | UV 20.4 | |
| 10 | 45.0 m | UV 20.4 | UV 20.4 | |
| 11 | 49.5 m | TVA 20.4 | TVA 20.4 | |
| 12 | 54.0 m | TV 20.4 | TV 20.4 | |
| 13 | 58.5 m | TV 20.4 | TV 20.4 | |
| 14 | 63.0 m | TV 20.4 | TV 20.4 | |
| 15 | 67.5 m | TV 20.4 | TV 20.4 | |
| 16 | 68.5 m | VR 2023 | VR 2023 | |
| 17 | 73.0 m | TV 23 | TV 23 | |
| 18 | 77.5 m | HTA 23 | HTA 23 | |
| 19 | 82.0 m | HT 23 | HT 23 | |
| 20 | 86.5 m | | HT 23 | |
| | | | | |
| Substructure | | KRF6 12-60/80 | KRF 16-80/100 | |
| Corner distance [m x m] | | 8.0 x 8.0 | 10.0 x 10.0 | |
| Substructure height [m] | | 2.9 | 3.3 | |
| Tower height [m] | | 84.9 | 89.8 | |
| Hook height above ground [m] | | 86.4 | 91.3 | |
| Wind category | C25 | | | |

3 Tower combinations

| Jib length | 25 m – 60 m | | | |
|------------------------------|-------------|---------------|-----|--|
| Item | | | | |
| 1 | 4.5 m | TFS 20 | | |
| 2 | 9.0 m | TFS 20.4 | | |
| 3 | 13.5 m | TFS 20.4 | | |
| 4 | 18.0 m | TFS 20.4 | | |
| 5 | 22.5 m | TFS 20.4 | | |
| 6 | 27.0 m | UVA 20.4 | | |
| 7 | 31.5 m | UV 20.4 | | |
| 8 | 36.0 m | UV 20.4 | | |
| 9 | 40.5 m | UV 20.4 | | |
| 10 | 45.0 m | UV 20.4 | | |
| 11 | 49.5 m | TVA 20.4 | | |
| 12 | 54.0 m | TV 20.4 | | |
| 13 | 58.5 m | TV 20.4 | | |
| 14 | 63.0 m | TV 20.4 | | |
| 15 | 64.0 m | VR 2023 | | |
| 16 | 68.5 m | TV 23 | | |
| 17 | 73.0 m | HTA 23 | | |
| 18 | 77.5 m | HT 23 | | |
| 19 | 82.0 m | HT 23 | | |
| 20 | 86.5 m | HT 23 | | |
| 21 | 87.7 m | VR 23/25-29 | | |
| 22 | 97.7 m | BT 29 | | |
| | | | | |
| | | | | |
| Substructure | | KRF 16-80/100 | | |
| Corner distance [m x m] | | 10.0 x 10.0 | | |
| Substructure height [m] | | 3.3 | | |
| Tower height [m] | | 101.0 | | |
| Hook height above ground [m] | | 102.5 | | |
| Wind category | | | C25 | |

3.8 Tower combinations on mobile cross frame (slewing section with UV 20 / TV 20 - connection)

| Jib length | 25 m – 60 m | | | |
|------------------------------|-------------|--------------|---------------|---------------|
| Item | | | | |
| 1 | 4.5 m | UV 20.4 | UV 20.4 | UV 20.4 |
| 2 | 9.0 m | UV 20.4 | UV 20.4 | UV 20.4 |
| 3 | 13.5 m | UV 20.4 | UV 20.4 | UV 20.4 |
| 4 | 18.0 m | UV 20.4 | UV 20.4 | UV 20.4 |
| 5 | 22.5 m | UV 20.4 | UV 20.4 | UV 20.4 |
| 6 | 27.0 m | UV 20.4 | UV 20.4 | UV 20.4 |
| 7 | 31.5 m | UV 20.4 | UV 20.4 | UV 20.4 |
| 8 | 36.0 m | UV 20.4 | UV 20.4 | UV 20.4 |
| 9 | 40.5 m | UV 20.4 | UV 20.4 | UV 20.4 |
| 10 | 45.0 m | UV 20.4 | UV 20.4 | UV 20.4 |
| 11 | 49.5 m | UV 20.4 | UV 20.4 | UV 20.4 |
| 12 | 54.0 m | TVA 20.4 | TVA 20.4 | TVA 20.4 |
| 13 | 58.5 m | TV 20.4 | TV 20.4 | TV 20.4 |
| 14 | 63.0 m | | TV 20.4 | TV 20.4 |
| 15 | 67.5 m | | TV 20.4 | TV 20.4 |
| | | | | |
| Substructure | | KRF 10-46/60 | KRF4 12-60/80 | KRF6 12-60/80 |
| Corner distance [m x m] | | 6.0 x 6.0 | 8.0 x 8.0 | 8.0 x 8.0 |
| Substructure height [m] | | 2.0 | 2.5 | 2.9 |
| Tower height [m] | | 60.5 | 70.0 | 70.4 |
| Hook height above ground [m] | | 62.0 | 71.5 | 71.9 |
| Wind category | | C25 | | |

3 Tower combinations

| Jib length | 25 m – 60 m | | | |
|------------------------------|-------------|---------------|---------------|--|
| Item | | | | |
| 1 | 4.5 m | UV 20.4 | UV 20.4 | |
| 2 | 9.0 m | UV 20.4 | UV 20.4 | |
| 3 | 13.5 m | UV 20.4 | UV 20.4 | |
| 4 | 18.0 m | UV 20.4 | UV 20.4 | |
| 5 | 22.5 m | UV 20.4 | UV 20.4 | |
| 6 | 27.0 m | UV 20.4 | UV 20.4 | |
| 7 | 31.5 m | UV 20.4 | UV 20.4 | |
| 8 | 36.0 m | UV 20.4 | UV 20.4 | |
| 9 | 40.5 m | UV 20.4 | UV 20.4 | |
| 10 | 45.0 m | UV 20.4 | UV 20.4 | |
| 11 | 49.5 m | TVA 20.4 | TVA 20.4 | |
| 12 | 54.0 m | TV 20.4 | TV 20.4 | |
| 13 | 58.5 m | TV 20.4 | TV 20.4 | |
| 14 | 63.0 m | TV 20.4 | TV 20.4 | |
| 15 | 67.5 m | TV 20.4 | TV 20.4 | |
| 16 | 68.5 m | VR 2023 | VR 2023 | |
| 17 | 73.0 m | TV 23 | TV 23 | |
| 18 | 77.5 m | HTA 23 | HTA 23 | |
| 19 | 82.0 m | HT 23 | HT 23 | |
| 20 | 86.5 m | | HT 23 | |
| | | | | |
| Substructure | | KRF6 12-60/80 | KRF 16-80/100 | |
| Corner distance [m x m] | | 8.0 x 8.0 | 10.0 x 10.0 | |
| Substructure height [m] | | 2.9 | 3.3 | |
| Tower height [m] | | 84.9 | 89.8 | |
| Hook height above ground [m] | | 86.4 | 91.3 | |
| Wind category | | C25 | | |

| Jib length | 25 m – 60 m | | | |
|------------------------------|-------------|---------------|-----|--|
| Item | | | | |
| 1 | 4.5 m | UV 20.4 | | |
| 2 | 9.0 m | UV 20.4 | | |
| 3 | 13.5 m | UV 20.4 | | |
| 4 | 18.0 m | UV 20.4 | | |
| 5 | 22.5 m | UV 20.4 | | |
| 6 | 27.0 m | UV 20.4 | | |
| 7 | 31.5 m | UV 20.4 | | |
| 8 | 36.0 m | UV 20.4 | | |
| 9 | 40.5 m | UV 20.4 | | |
| 10 | 45.0 m | UV 20.4 | | |
| 11 | 49.5 m | TVA 20.4 | | |
| 12 | 54.0 m | TV 20.4 | | |
| 13 | 58.5 m | TV 20.4 | | |
| 14 | 63.0 m | TV 20.4 | | |
| 15 | 64.0 m | VR 2023 | | |
| 16 | 68.5 m | TV 23 | | |
| 17 | 73.0 m | HTA 23 | | |
| 18 | 77.5 m | HT 23 | | |
| 19 | 82.0 m | HT 23 | | |
| 20 | 86.5 m | HT 23 | | |
| 21 | 87.7 m | VR 23/25-29 | | |
| 22 | 97.7 m | BT 29 | | |
| | | | | |
| Substructure | | KRF 16-80/100 | | |
| Corner distance [m x m] | | 10.0 x 10.0 | | |
| Substructure height [m] | | 3.3 | | |
| Tower height [m] | | 101.0 | | |
| Hook height above ground [m] | | 102.5 | | |
| Wind category | | | C25 | |

3 Tower combinations

3.9 Tower combinations on undercarriage (slewing section with TFS 20 - connection)

| Jib length | | 25 m – 60 m | | | |
|------------------------------|--------|-------------|-----------|------------|-----------|
| Item | | | | | |
| 1 | 4.5 m | TFS 20 | TFS 20 | TFS 20 | TFS 20 |
| 2 | 9.0 m | TFS 20 | TFS 20 | TFS 20 | TFS 20 |
| 3 | 13.5 m | TFS 20.4 | TFS 20.4 | TFS 20.4 | TFS 20.4 |
| 4 | 18.0 m | TFS 20.4 | TFS 20.4 | TFS 20.4 | TFS 20.4 |
| 5 | 22.5 m | TFS 20.4 | TFS 20.4 | TFS 20.4 | TFS 20.4 |
| 6 | 27.0 m | TFS 20.4 | TFS 20.4 | TFS 20.4 | TFS 20.4 |
| 7 | 31.5 m | UVA 20.4 | TFS 20.4 | TFS 20.4 | TFS 20.4 |
| 8 | 36.0 m | | UVA 20.4 | UVA 20.4 | UVA 20.4 |
| 9 | 40.5 m | | | TVA 20.4 | UV 20.4 |
| 10 | 45.0 m | | | | TVA 20.4 |
| | | | | | |
| Substructure | | UW 260.1 | UW 260.1 | UW 260.2 | UW 260.2 |
| Corner distance [m x m] | | 5.0 x 6.79 | 6.0 x 6.0 | 5.0 x 6.79 | 6.0 x 6.0 |
| Substructure height [m] | | 4.5 | 4.5 | 4.5 | 4.5 |
| Tower height [m] | | 36.0 | 40.5 | 45.0 | 49.5 |
| Hook height above ground [m] | | 37.5 | 42.0 | 46.5 | 51.0 |
| Wind category | | C25 | | | |

| Jib length | 25 m – 60 m | | | |
|------------------------------|-------------|------------|-----------|------------|
| Item | | | | |
| 1 | 4.5 m | TFS 20 | TFS 20 | TFS 20 |
| 2 | 9.0 m | TFS 20 | TFS 20 | TFS 20 |
| 3 | 13.5 m | TFS 20.4 | TFS 20.4 | TFS 20.4 |
| 4 | 18.0 m | TFS 20.4 | TFS 20.4 | TFS 20.4 |
| 5 | 22.5 m | TFS 20.4 | TFS 20.4 | TFS 20.4 |
| 6 | 27.0 m | TFS 20.4 | TFS 20.4 | TFS 20.4 |
| 7 | 31.5 m | TFS 20.4 | TFS 20.4 | TFS 20.4 |
| 8 | 36.0 m | UVA 20.4 | UVA 20.4 | UVA 20.4 |
| 9 | 40.5 m | UV 20.4 | UV 20.4 | UV 20.4 |
| 10 | 45.0 m | UV 20.4 | UV 20.4 | UV 20.4 |
| 11 | 49.5 m | TVA 20.4 | UV 20.4 | TVA 20.4 |
| 12 | 54.0 m | | TVA 20.4 | TV 20.4 |
| 13 | 58.5 m | | | TV 20.4 |
| 14 | 63.0 m | | | TVÜ 20.4 |
| 15 | 67.5 m | | | UVA 25 |
| Substructure | | UW 260.3 | UW 260.3 | UW 480 |
| Corner distance [m x m] | | 5.0 x 6.79 | 6.0 x 6.0 | 5.0 x 6.79 |
| Substructure height [m] | | 4.5 | 4.5 | 5.0 |
| Tower height [m] | | 54.0 | 58.5 | 72.5 |
| Hook height above ground [m] | | 55.5 | 60.0 | 74.0 |
| Wind category | | C25 | | |

3 Tower combinations



3.10 Tower combinations on undercarriage (slewing section with UV 20 / TV 20 - connection)

| Jib length | | 25 m – 60 m | | | |
|------------------------------|--------|-------------|-----------|------------|-----------|
| Item | | | | | |
| 1 | 4.5 m | UV 20.4 | UV 20.4 | UV 20.4 | UV 20.4 |
| 2 | 9.0 m | UV 20.4 | UV 20.4 | UV 20.4 | UV 20.4 |
| 3 | 13.5 m | UV 20.4 | UV 20.4 | UV 20.4 | UV 20.4 |
| 4 | 18.0 m | UV 20.4 | UV 20.4 | UV 20.4 | UV 20.4 |
| 5 | 22.5 m | UV 20.4 | UV 20.4 | UV 20.4 | UV 20.4 |
| 6 | 27.0 m | UV 20.4 | UV 20.4 | UV 20.4 | UV 20.4 |
| 7 | 31.5 m | UV 20.4 | UV 20.4 | UV 20.4 | UV 20.4 |
| 8 | 36.0 m | | UV 20.4 | UV 20.4 | UV 20.4 |
| 9 | 40.5 m | | | TVA 20.4 | UV 20.4 |
| 10 | 45.0 m | | | | TVA 20.4 |
| | | | | | |
| Substructure | | UW 260.1 | UW 260.1 | UW 260.2 | UW 260.2 |
| [m x m] | | 5.0 x 6.79 | 6.0 x 6.0 | 5.0 x 6.79 | 6.0 x 6.0 |
| Substructure height [m] | | 4.5 | 4.5 | 4.5 | 4.5 |
| Tower height [m] | | 36.0 | 40.5 | 45.0 | 49.5 |
| Hook height above ground [m] | | 37.5 | 42.0 | 46.5 | 51.0 |

| Jib length | 25 m – 60 m | | | | |
|------------------------------|-------------|------------|-----------|-----------|--|
| Item | | | | | |
| 1 | 4.5 m | UV 20.4 | UV 20.4 | UV 20.4 | |
| 2 | 9.0 m | UV 20.4 | UV 20.4 | UV 20.4 | |
| 3 | 13.5 m | UV 20.4 | UV 20.4 | UV 20.4 | |
| 4 | 18.0 m | UV 20.4 | UV 20.4 | UV 20.4 | |
| 5 | 22.5 m | UV 20.4 | UV 20.4 | UV 20.4 | |
| 6 | 27.0 m | UV 20.4 | UV 20.4 | UV 20.4 | |
| 7 | 31.5 m | UV 20.4 | UV 20.4 | UV 20.4 | |
| 8 | 36.0 m | UV 20.4 | UV 20.4 | UV 20.4 | |
| 9 | 40.5 m | UV 20.4 | UV 20.4 | UV 20.4 | |
| 10 | 45.0 m | UV 20.4 | UV 20.4 | UV 20.4 | |
| 11 | 49.5 m | TVA 20.4 | UV 20.4 | TVA 20.4 | |
| 12 | 54.0 m | | TVA 20.4 | TV 20.4 | |
| 13 | 58.5 m | | | TV 20.4 | |
| 14 | 63.0 m | | | TVÜ 20.4 | |
| 15 | 67.5 m | | | UVA 25 | |
| | | | | | |
| Substructure | | UW 260.3 | UW 260.3 | UW 480 | |
| [m x m] | | 5.0 x 6.79 | 6.0 x 6.0 | 8.0 x 8.0 | |
| Substructure height [m] | | 4.5 | 4.5 | 5.0 | |
| Tower height [m] | | 54.0 | 58.5 | 72.5 | |
| Hook height above ground [m] | | 55.5 | 60.0 | 74.0 | |

4 Foundation loads / central ballast weights / corner loads in compliance with EN 14439 / EN 13001

4 Foundation loads / central ballast weights / corner loads in compliance with EN 14439 / EN 13001

| | |
|---|---|
|  | <p style="text-align: center;">⚠ DANGER</p> <p>Usage of incorrect tower combinations. The slewing tower crane may overturn.</p> <ol style="list-style-type: none"> 1) Use the specified tower combinations. 2) If you need another tower combination that is not specified here, please contact WOLFFKRAN to get an approved alternative setup in writing. |
|  | <p style="text-align: center;">NOTICE</p> <p>If you need foundation loads for tower combination with tower element TV 25 and UV 25, please contact WOLFFKRAN to get an approved alternative setup.</p> |

Jib positions

The corner loads are given for two jib positions with the maximum corner load resulting from jib position 1.

For square setup, the following equation is true: $a = b$

For rectangular setup, the following equation is true: $a > b$

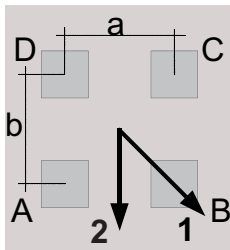

Cross frame or cross frame element

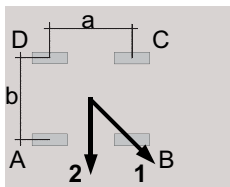

Undercarriage

NOTICE! For undercarriage details, please refer to the relevant operating manual.

Wind load with crane out of service

The stability for stormy weather is calculated on the basis of wind region C (EN 13001-2). The reference wind speed for zone C is 28 m/s (10 m above ground, averaged over 10 minutes). As a basis, a recurrence interval of 25 years is used. As a basis, a recurrence interval of 25 years is used.

4 Foundation loads / central ballast weights / corner loads in compliance with EN 14439 / EN 13001

Please contact WOLFFKRAN for stability calculations in other wind regions.

For information on the different substructures, refer to Section 5 of the Operating Manual.

4.1 Foundation loads jib 25 m - 60 m

Slewing section 6023 *clear* with 25 m – 60 m jib on foundation.
Slewing tower crane without climbing device.

Foundation load in compliance with EN 14439 / EN 13001 – typical loads

Includes all dynamical factors under consideration of second-order theory for stationary slewing tower cranes on concrete foundation in compliance with a tower combination without climbing device.

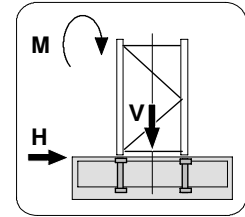



| HH | | Crane in service | | | Crane out of service | | | Assembly | | |
|---|-------|-------------------------|------|------|----------------------|------|------|----------|------|------|
| 4 | 2 | Slewing torque: 240 kNm | | | Wind category C25 | | | M | V | H |
| STR | STR | M | V | H | M | V | H | M | V | H |
| [m] | [m] | [kNm] | [kN] | [kN] | [kNm] | [kN] | [kN] | [kNm] | [kN] | [kN] |
| - | 6.0 | 1540 | 535 | 17 | 1330 | 436 | 28 | 1510 | 259 | 5 |
| - | 10.5 | 1630 | 549 | 19 | 1470 | 450 | 32 | 1540 | 273 | 6 |
| - | 15.0 | 1730 | 563 | 20 | 1640 | 464 | 37 | 1570 | 287 | 7 |
| - | 19.5 | 1840 | 578 | 21 | 1820 | 478 | 41 | 1610 | 301 | 8 |
| - | 24.0 | 1970 | 592 | 23 | 2040 | 492 | 46 | 1660 | 315 | 9 |
| - | 28.5 | 2100 | 606 | 24 | 2280 | 506 | 50 | 1720 | 329 | 9 |
| - | 33.0 | 2260 | 620 | 26 | 2560 | 520 | 55 | 1780 | 343 | 10 |
| - | 37.5 | 2430 | 634 | 27 | 2870 | 534 | 59 | 1840 | 357 | 11 |
| - | 42.0 | 2630 | 648 | 28 | 3210 | 548 | 64 | 1920 | 371 | 12 |
| - | 46.5 | 2830 | 667 | 30 | 3580 | 567 | 69 | 2000 | 391 | 13 |
| - | 51.0 | 3040 | 685 | 31 | 3980 | 585 | 74 | 2080 | 409 | 14 |
| - | 55.5 | 3290 | 704 | 33 | 4430 | 604 | 78 | 2180 | 427 | 15 |
| - | 60.0 | 3460 | 746 | 36 | 4910 | 755 | 121 | 2250 | 470 | 16 |
| - | 64.5 | 3710 | 775 | 37 | 5730 | 783 | 130 | 2350 | 498 | 17 |
| - | 69.0 | 3980 | 803 | 39 | 6650 | 811 | 140 | 2460 | 526 | 18 |
| - | 70.0 | 4010 | 832 | 41 | 6970 | 869 | 146 | 2480 | 556 | 19 |
| - | 74.5 | 4290 | 863 | 43 | 7990 | 899 | 157 | 2590 | 586 | 20 |
| - | 79.0 | 4590 | 893 | 45 | 9110 | 929 | 168 | 2720 | 617 | 21 |
| - | 83.5 | 4840 | 961 | 48 | 10260 | 993 | 182 | 2840 | 685 | 23 |
| - | 88.0 | 5170 | 1000 | 50 | 11550 | 1033 | 193 | 2970 | 724 | 24 |
| - | 90.3 | 5260 | 1047 | 52 | 11850 | 1055 | 200 | 3020 | 770 | 25 |
| - | 92.5 | 5530 | 1040 | 52 | 12720 | 1048 | 203 | 3120 | 763 | 25 |
| - | 94.8 | 5620 | 1086 | 54 | 13540 | 1118 | 214 | 3180 | 810 | 26 |
| - | 99.3 | 6020 | 1125 | 56 | 14850 | 1134 | 224 | 3340 | 849 | 27 |
| Tower combination with base tower element BT 29 | | | | | | | | | | |
| - | 99.2 | 5920 | 1169 | 57 | 14800 | 1178 | 228 | 3330 | 893 | 28 |
| - | 103.7 | 5980 | 1287 | 59 | 16410 | 1224 | 242 | 3470 | 908 | 29 |



Caption

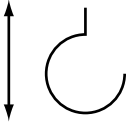
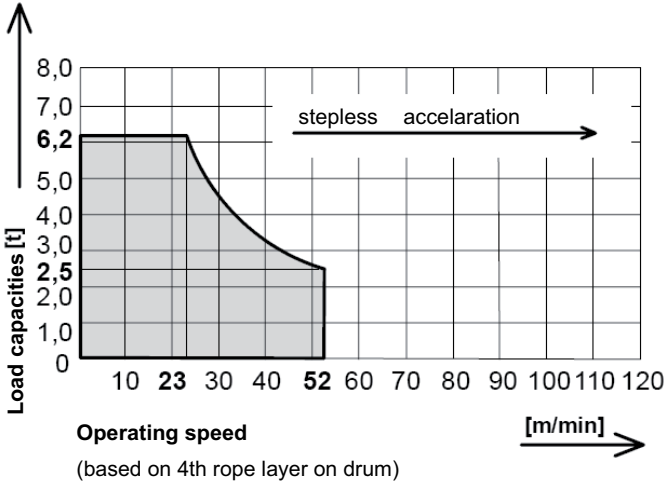
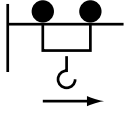
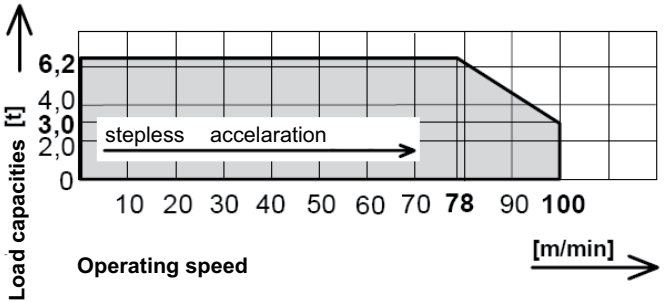

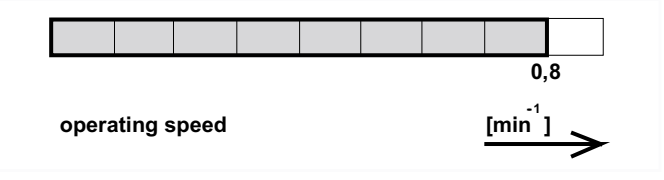
| | | | | | |
|-----|-----------------|----|---------------|------|-----------------|
| HH: | Hook height | V: | Vertical load | STR: | Number of falls |
| H: | Horizontal load | M: | Torque | | |

5 Operating speeds

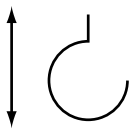
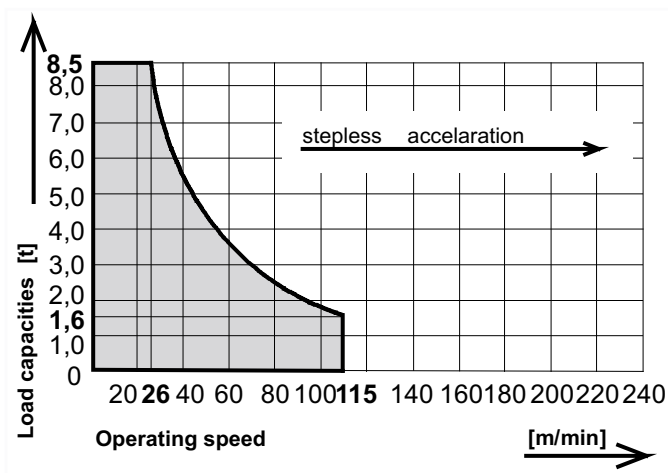
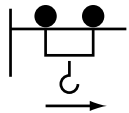
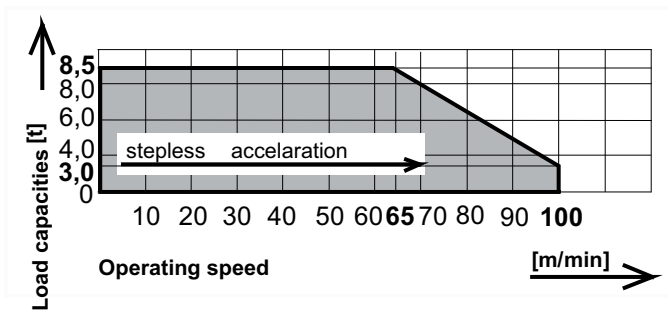
| Drive unit [type] | Operating speed Carrying load | | Hook travel distance max. [m] | Power [kW] | Total connected load [kVA] |
|---|--|---|-------------------------------|------------|---|
| Hw628FU | Lifting |  | 190 | 28 | 47.0 Total connected load at coincidence factor of 0.7 |
|  |  <p>Load capacities [t]</p> <p>Operating speed [m/min]</p> <p>(based on 4th rope layer on drum)</p> | | | | |
| KW | Trolley movement | | | 7.5 | |
|  |  <p>Load capacities [t]</p> <p>Operating speed [m/min]</p> | | | | |
| SG | Slewing | | | 7.5 | |
|  |  <p>operating speed [min⁻¹]</p> | | | | |

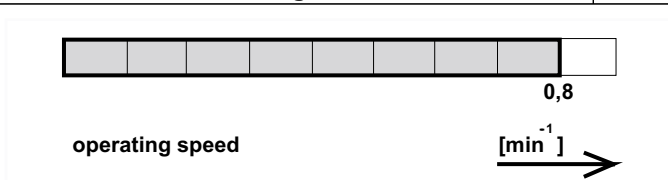
5 Operating speeds

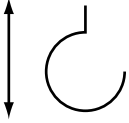
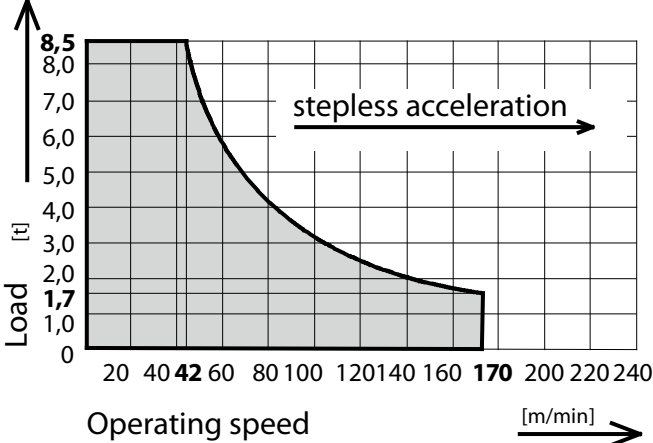
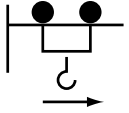
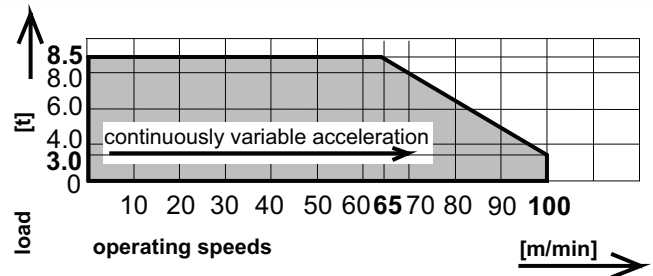
| Drive unit [type] | Operating speed Carrying load | | Hook travel distance max. [m] | Power [kW] | Total connected load [kVA] |
|---|--|---|-------------------------------|------------|---|
| Hw845FU | Lifting |  | 190 | 45 | 62.0 Total connected load at coincidence factor of 0.7 |
|  |  | | | | |
| KW | Trolley movement | | | 7.5 | |
|  |  | | | | |
| SG | Slewing | | | 7.5 | |
|  |  | | | | |









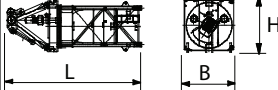
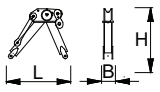
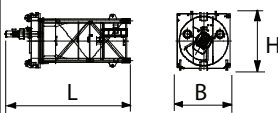
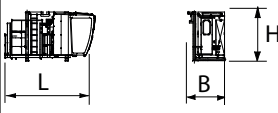
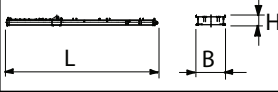
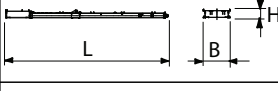
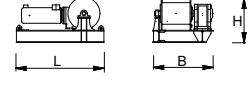
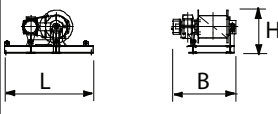
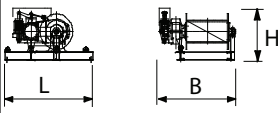
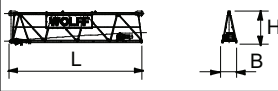
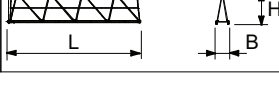

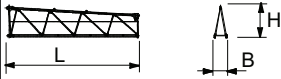
| Drive unit [type] | Operating speed Carrying load | | Hook travel distance max. [m] | Power [kW] | Total connected load [kVA] |
|---|--|---|-------------------------------|------------|---|
| Hw875FU | Lifting |  | 460 | 75 | 90.0 Total connected load at coincidence factor of 0.7 |
|  |  | | | | |
| KW | Trolley movement | | | 7.5 | |
|  |  | | | | |
| SG | Slewing | | | 7.5 | |
|  |  | | | | |

6 Package list

6 Package list

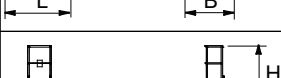
6.1 Package list 6023

| Quantity | Description | Package | L [m] | W [m] | H [m] | Weight [kg] | Volume [m ³] | | | | | |
|----------|--|---|---|-------|-------|-------------|--------------------------|------|------|------|------|-------|
| 1 | Tower head section, complete with slewing frame, ball race bearing, slewing gear and slip ring system |  | with UV 20 / TV 20 lower part of tower head section | | | | | 6.67 | 2.30 | 2.54 | 9065 | 38.97 |
| | | | with TFS 20 lower part of tower head section | | | | | 6.67 | 2.30 | 2.54 | 8325 | 38.97 |
| 1 | Tower head section upper part with stay parts |  | 2.33 | 0.58 | 2.81 | 1300 | 3.80 | | | | | |
| | Tower head section lower part with slewing frame, ball race bearing, slewing gear and slip ring system |  | with UV 20 / TV 20 lower part of tower head section | | | | | 5.97 | 2.30 | 2.54 | 7765 | 34.88 |
| | | | with TFS 20 lower part of tower head section | | | | | 5.97 | 2.30 | 2.54 | 7025 | 34.88 |
| 1 | Driver's cab with driver's cab suspension |  | 4.82 | 1.96 | 2.55 | 2580 | 24.10 | | | | | |
| 1 | Counterjib with stay parts and standard railings |  | 14.04 | 2.30 | 0.80 | 6840 | 25.84 | | | | | |
| | Counterjib without ballast carrier and without loose items |  | 11.87 | 2.30 | 0.70 | 5280 | 19.11 | | | | | |
| 1 | Hoist winch platform Hw628FU (incl. 200 m hoisting rope) |  | 2.17 | 1.50 | 1.12 | 2175 | 3.65 | | | | | |
| 1 | Hoist winch platform Hw845FU (incl. 200 m hoisting rope) |  | 2.17 | 1.57 | 1.04 | 2140 | 3.54 | | | | | |
| 1 | Hoist winch platform Hw875FU (incl. 200 m hoisting rope) |  | 2.17 | 1.88 | 1.18 | 2500 | 4.82 | | | | | |
| 1 | Jib element 1 with traverse gear |  | 10.32 | 1.20 | 2.55 | 2952 | 31.64 | | | | | |
| 1 | Jib element 2 |  | 5.31 | 1.20 | 2.38 | 1033 | 15.17 | | | | | |

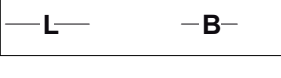
| Quantity | Description | Package | L [m] | W [m] | H [m] | Weight [kg] | Volume [m³] |
|----------|------------------------|---|-------|-------|-------|-------------|-------------|
| 1 | Jib element 3 |  | 10.29 | 1.20 | 2.34 | 1600 | 28.90 |
| 1 | Jib element 4 |  | 5.27 | 1.20 | 1.74 | 775 | 11.00 |
| | Jib element 5 |  | 2.77 | 1.20 | 1.74 | 470 | 5.78 |
| 1 | Jib element 6 |  | 10.25 | 1.20 | 1.72 | 1365 | 21.16 |
| 1 | Jib element 7 |  | 10.17 | 1.20 | 1.70 | 1045 | 20.75 |
| 1 | Jib element 8 |  | 10.17 | 1.20 | 1.70 | 800 | 20.75 |
| 1 | Rope swivel cross-beam |  | 0.99 | 1.09 | 0.45 | 126 | 0.49 |
| 1 | Trolley LK 8 |  | 1.87 | 1.42 | 0.95 | 295 | 2.52 |
| 1 | Maintenance cage |  | 0.75 | 0.58 | 1.69 | 55 | 0.74 |
| 1 | Hook block U6 (8) |  | 0.50 | 0.22 | 1.11 | 350 | 0.12 |
| 1 | Standard railings |  | 2.60 | 1.10 | 0.65 | 300 | 1.86 |
| 1 | Box (small parts) |  | 0.63 | 0.50 | 0.38 | 100 | 1.12 |

7 Assembly weights

7 Assembly weights

7.1 Counterweight blocks

| | |
|---|--|
|  | NOTICE |
| | <p>The described diagrams of the concrete counterweights and central ballast blocks only show sketches. Have them issue the reinforcement charts by experts.</p> |

7.1.1 Counterweight block, 2.7 t

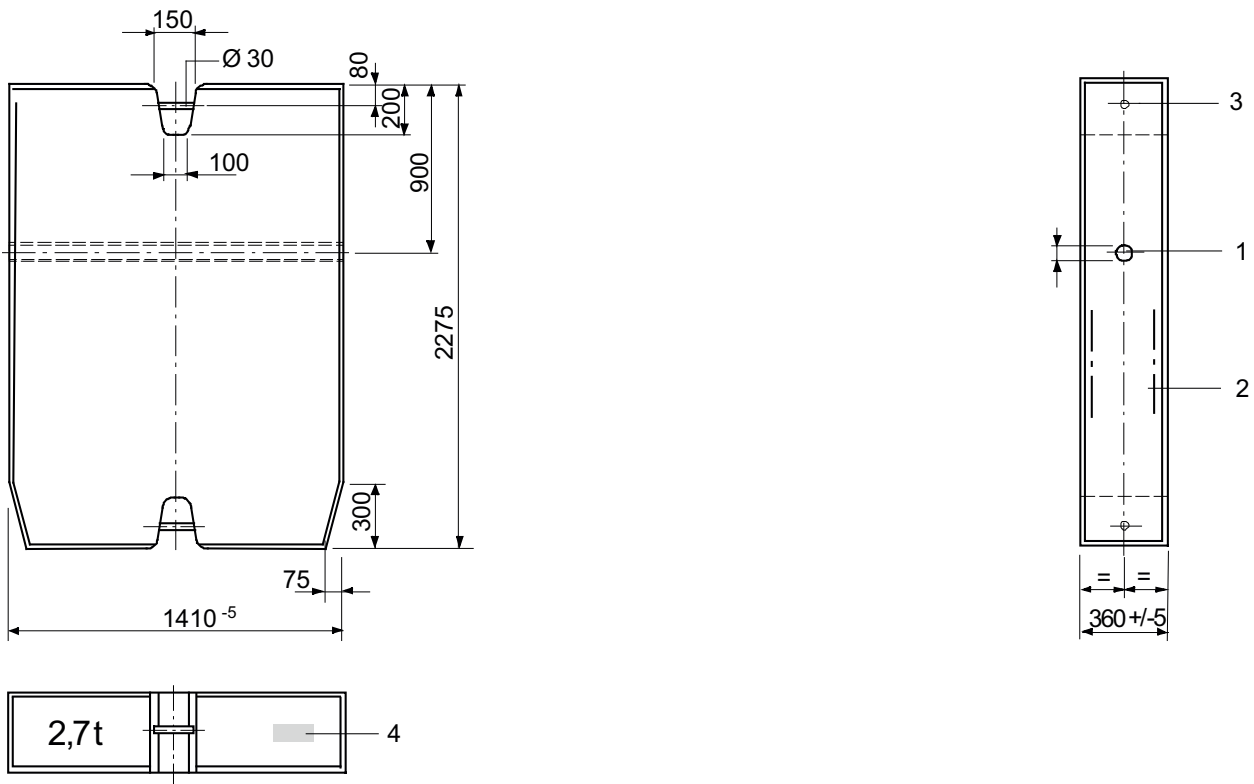

Data counterweight block 2.7 t

| Item | Data |
|---------------------------------|---|
| Material | Concrete, min. C 20/25 |
| Max. permitted weight tolerance | +/- 3 % |
| Order number | 30021887 |
| 1 | Connection for stub shaft (Ø 40x 215 Item no.: 30024871) |
| 2 | Structural steel reinforcement |
| 3 | Suspension |
| 4 | Component identifier |

7 Assembly weights

7.1.2 Counterweight block, 3.7 t

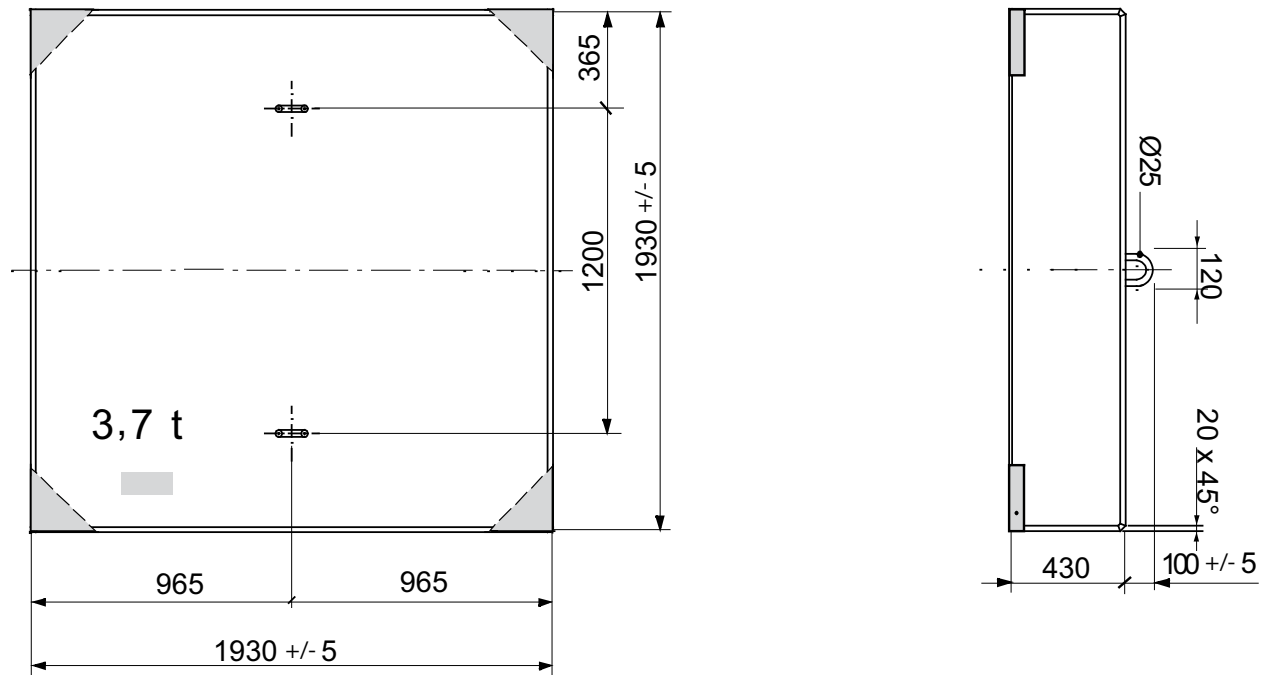

Data counterweight block 3.7 t

| Item | Data |
|---------------------------------|------------------------|
| Material | Concrete, min. C 20/25 |
| Max. permitted weight tolerance | +/- 3 % |
| Order number | 962-2-029759 |
| 1 | Corner guard |
| 2 | Suspension |
| 3 | Component identifier |

7.2 Total weight jib assembly

Trolley jib, complete: Trolley, trolley ropes, hook block, standard railings and rope swivel crossbeam

| Jib length (m) | Weight (kg) WOLFF 6023 clear |
|-----------------------|---|
| 60.0 | 10400 |
| 57.5 | 10100 |
| 55.0 | 9620 |
| 52.5 | 9500 |
| 50.0 | 9600 |
| 47.5 | 9300 |
| 45.0 | 8820 |
| 42.5 | 8700 |
| 40.0 | 8550 |
| 37.5 | 8250 |
| 35.0 | 7770 |
| 32.5 | 7650 |
| 30.0 | 7170 |
| 27.5 | 6870 |
| 25.0 | 6390 |

7 Assembly weights

7.3 Assembly weight slewing section

| Module | Crane parts | Weight [kg] | |
|--|---|-------------|-------|
| Tower head section complete – Tower connection UV 20 / TV 20 tower head section lower part | | | 9065 |
| | ▪ Tower head section upper part including brace plates | 1300 | |
| | ▪ Tower head section lower part including slewing frame, ball race bearing, slewing gears, standard railings and slip ring system | 7765 | |
| Tower head section complete – Tower connection TFS 20 Lower part of tower head section | | | 8325 |
| | ▪ Tower head section upper part including brace plates | 1300 | |
| | ▪ Tower head section lower part including slewing frame, ball race bearing, slewing gears, standard railings and slip ring system | 7025 | |
| Operator cabinet platform, complete | | | 2580 |
| | ▪ Driver's cab including control cabinet, resistor and driver's cab suspension | | |
| Counterjib with Hw628FU, complete | | | 12300 |
| | ▪ Counterjib with brace plates, standard railings and ballast frame | 6840 | |
| | ▪ Hoist winch platform Hw628FU | 1760 | |
| | ▪ Concrete counterweight block 3.7 t (below hoist winch platform) | 3700 | |
| Counter jib with Hw845FU, complete | | | 12575 |
| | ▪ Counterjib with brace plates, standard railings and ballast frame | 6840 | |
| | ▪ Hoist winch platform Hw845FU | 2035 | |
| | ▪ Concrete counterweight block 3.7 t (below hoist winch platform) | 3700 | |
| Counter jib with Hw875FU, complete | | | 12915 |
| | ▪ Counterjib with brace plates, standard railings and ballast frame | 6840 | |
| | ▪ Hoist winch platform Hw875FU | 2375 | |
| | ▪ Concrete counterweight block 3.7 t (below hoist winch platform) | 3700 | |

7.4 Assembly weight cross frame

| Module | Crane parts | Weight [kg] |
|--|--|-------------|
| Cross frame KR 6-40 (without accessories) | | |
| (4.0 m x 4.0 m) | ▪ 4 bolted spigots AZ 93.4 | 200 |
| | ▪ 4 bolted spigots AZ 93.4 E 15 | 240 |
| Cross frame KR 7-32 (without accessories) | | |
| (3.2 m x 3.2 m) | ▪ 4 bolted spigots AZ 85 E 20.5 | 210 |
| | ▪ 4 bolted spigots AZ 93.4 E 15 | 240 |
| | ▪ 4 bolted spigots AZ 120 M | 292 |
| Cross frame KR 7 - 32 (without accessories) | | |
| (3.2 m x 3.2 m) | ▪ 4 bolted spigots AZ 85 E 20.5 | 210 |
| | ▪ 4 bolted spigots AZ 93.4 E 15 | 240 |
| | ▪ 4 bolted spigots AZ 120 M | 292 |
| Cross frame KR 7 - 32/46 (without accessories) | | |
| (4.6 m x 4.6 m) | ▪ 4 bolted spigots AZ 85 E 20.5 | 210 |
| | ▪ 4 bolted spigots AZ 93.4 E 15 | 240 |
| | ▪ 4 bolted spigots AZ 120 M | 292 |
| Cross frame KR 8- 46 (without accessories) | | |
| (4.6 m x 4.6 m) | ▪ 4 bolted spigots AZ 85 E 20.5 | 210 |
| | ▪ 4 bolted spigots AZ 93.4 E 15 | 240 |
| | ▪ 4 bolted spigots AZ 120 M | 292 |
| Cross frame KR 10- 46 (without accessories) | | |
| (4.6 m x 4.6 m) | ▪ 4 bolted spigots AZR 120 E 15.5 | 552 |
| | ▪ 4 bolted spigots AZ 140 M | 698 |
| Cross frame KR 16 - 46/ 60 (without accessories) | | |
| (6.0 m x 6.0 m) | ▪ 4 bolted spigots AZR 120 E 15.5 | 552 |
| | ▪ 4 bolted spigots AZ 140 M | 698 |
| Cross frame KRV 10-60 (without accessories) | | |
| (6.0 m x 6.0 m) | ▪ 4 bolted spigots AZ 120 E 15,5 KRV 10-60 | 730 |
| | ▪ 4 bolted spigots AZ 140 M KRV 10-60 | 790 |
| | ▪ 4 bolted spigots AZ 140 E 10 KRV 10-60 | 790 |
| | ▪ 4 bolted spigots AZ 140 M KRV 10-60 | 715 |
| Cross frame KR 12-60 (without accessories) | | |
| (6.0 m x 6.0 m) | ▪ 4 bolted spigots AZ 120 E 15,5 KR 12-60 | 730 |
| | ▪ 4 bolted spigots AZ 140 M KR 12-60 | 790 |
| | ▪ 4 bolted spigots AZ 140 E10 KR 12-60 | 790 |

7 Assembly weights

| Module | Crane parts | Weight [kg] | |
|--|---|-------------|-------|
| | ▪ 4 bolted spigots AZ 156 M KR 12-60 | 845 | |
| | ▪ 4 bolted spigots AZ 140 E17 KR 12-60 | 875 | |
| | ▪ 4 bolted spigots AZ 160 M KR 12-60 | 905 | |
| Cross frame KR 12-60/ 80 (without accessories) | | | 19260 |
| (8.0 m x 8.0 m) | ▪ 4 bolted spigots AZ 120 E 15,5 KR 12-60 | 730 | |
| | ▪ 4 bolted spigots AZ 140 M KR 12-60 | 790 | |
| | ▪ 4 bolted spigots AZ 140 E10 KR 12-60 | 790 | |
| | ▪ 4 bolted spigots AZ 156 M KR 12-60 | 845 | |
| | ▪ 4 bolted spigots AZ 140 E17 KR 12-60 | 875 | |
| | ▪ 4 bolted spigots AZ 160 M KR 12-60 | 905 | |
| Cross frame KR HEB 700 - 4 (without accessories) | | | 4450 |
| (4.0 m x 4.0 m) | ▪ 4 bolted spigots AZ 93.4 | 240 | |
| Cross frame KR HEB 700 - 5 (without accessories) | | | 5410 |
| (5.0 m x 5.0 m) | ▪ 4 bolted spigots AZ 93.4 | 240 | |
| Cross frame KR HEB 800 - 5 (without accessories) | | | 5860 |
| (5.0 m x 5.0 m) | ▪ 4 bolted spigots AZ 120 M | 292 | |
| Cross frame KR HEB 800 - 6 (without accessories) | | | 6600 |
| (6.0 m x 6.0 m) | ▪ 4 bolted spigots AZ 120 M | 292 | |
| Supporting frame SR 150 (without accessories) | | | 5460 |
| (4.0 m x 4.0 m) | ▪ 4 bolted spigots AZ 85 E 20.5 | 210 | |
| | ▪ 4 bolted spigots AZ 93.4 E 15 | 240 | |
| | ▪ 4 bolted spigots AZ 120 M | 292 | |
| Cross frame KR 1000- 8 (without accessories) | | | 14630 |
| (8.0 m x 8.0 m) | ▪ 4 bolted spigots AZ 140 E | 684 | |
| | ▪ 4 bolted spigots AZ 156 M | 748 | |
| Cross frame KR 16- 80 (without accessories) | | | 21450 |
| (8.0 m x 8.0 m) | ▪ 4 bolted spigots AZ 140 E KR 16-80 | 620 | |
| | ▪ 4 bolted spigots AZ 156 M KR 16-80 | 680 | |
| | ▪ 4 bolted spigots AZ 156S M KR 16-80 | 675 | |
| Cross frame KR 16 - 80 / 100 (without accessories) | | | 25400 |
| (10.0 m x 10.0 m) | ▪ 4 bolted spigots AZ 140 E KR 16-80 | 620 | |
| | ▪ 4 bolted spigots AZ 156 M KR 16-80 | 680 | |
| | ▪ 4 bolted spigots AZ 156S M KR 16-80 | 675 | |

7.5 Assembly weights traveling cross frame

| Module | Crane parts | Weight [kg] | |
|--|---|-------------|-------|
| Mobile cross frame KRF 10 – 46/60 complete | | | 17500 |
| (6.0 m x 6.0 m) | ▪ Cross frame | 7000 | |
| | ▪ Drive gear corners | 2385 | |
| | ▪ Backing braces | 1510 | |
| | ▪ Subframe | 5645 | |
| | ▪ Platforms + ladders | 510 | |
| | ▪ Control cabinet | 130 | |
| | ▪ small items | 320 | |
| | ▪ Set of bolted spigots AZR 120 E 15,5 | 552 | |
| | ▪ Set of bolted spigots AZ 140 M | 698 | |
| Traveling cross frame KRF4 12-60/80 complete | | | 32300 |
| (8.0 m x 8.0 m) | ▪ Cross frame | 14170 | |
| | ▪ Backing braces | 2875 | |
| | ▪ Drive gear corners | 4560 | |
| | ▪ Subframe | 9380 | |
| | ▪ Platforms and ladders | 255 | |
| | ▪ Control cabinet | 130 | |
| | ▪ small items | 930 | |
| | ▪ 4 bolted spigots AZ 120 E 15,5 KR 12-60 | 730 | |
| | ▪ 4 bolted spigots AZ 140 M KR 12-60 | 790 | |
| | ▪ 4 bolted spigots AZ 140 E10 KR 12-60 | 790 | |
| | ▪ 4 bolted spigots AZ 156 M KR 12-60 | 845 | |
| | ▪ 4 bolted spigots AZ 140 E17 KR 12-60 | 875 | |
| | ▪ 4 bolted spigots AZ 160 M KR 12-60 | 905 | |

7 Assembly weights

| Module | Crane parts | Weight [kg] |
|---|---|-------------|
| Traveling cross frame KRF6 12-60/80 complete (8.0 m x 8.0 m) | | 41200 |
| | ▪ Cross frame | 14170 |
| | ▪ Backing braces | 2875 |
| | ▪ Drive gear corners | 4560 |
| | ▪ Subframe | 18270 |
| | ▪ Platforms and ladders | 255 |
| | ▪ Control cabinet | 130 |
| | ▪ small items | 940 |
| | ▪ 4 bolted spigots AZ 120 E 15,5 KR 12-60 | 730 |
| | ▪ 4 bolted spigots AZ 140 M KR 12-60 | 790 |
| | ▪ 4 bolted spigots AZ 140 E10 KR 12-60 | 790 |
| | ▪ 4 bolted spigots AZ 156 M KR 12-60 | 845 |
| | ▪ 4 bolted spigots AZ 140 E17 KR 12-60 | 875 |
| | ▪ 4 bolted spigots AZ 160 M KR 12-60 | 905 |

7.6 Assembly weight cross frame elements

| Module | Crane parts | Weight [kg] | |
|---|---|-------------|-------|
| Cross frame element KRE 138, complete | | | 3800 |
| | ▪ Cross frame platform with lifting beam, corner plates and transport locks | 2100 | |
| | ▪ Mast base with diagonal struts | 1700 | |
| Cross frame element KRE 250 complete | | | 5750 |
| | ▪ Cross frame platform with hinged section, corner plates and transport locks | 2730 | |
| | ▪ Mast base with diagonal struts and tie rods | 3020 | |
| Cross frame element KRE 260.1, complete | | | 8100 |
| | ▪ Cross frame platform with hinged section, corner plates and transport locks | 4320 | |
| | ▪ Mast base with diagonal struts and tie rods | 3780 | |
| Cross frame element KRE 260.2, complete | | | 10900 |
| | ▪ Cross frame platform with hinged section, corner plates and transport locks | 5455 | |
| | ▪ Mast base with diagonal struts and tie rods | 5445 | |
| Cross frame element KRE 480 complete | | | 24250 |
| | ▪ Mast base | 7100 | |
| | ▪ Hinged sections with corner plates | 6250 | |
| | ▪ Diagonal struts and ballast carrier | 9260 | |
| | ▪ Assembly platform, ladder, and small parts | 1640 | |

7 Assembly weights

7.7 Assembly weight undercarriage

| Module | Crane parts | Weight [kg] | |
|----------------------------------|--|-------------|-------|
| Bogie truck UW 138, complete | | | 5750 |
| | ▪ Undercarriage platform with mounting device, spacers and subframes | 3970 | |
| | ▪ Mast base with diagonal struts | 1780 | |
| Undercarriage UW 250, complete | | | 8800 |
| | ▪ Undercarriage platform with hinged sections, subframes and transport locks | 5600 | |
| | ▪ Mast base with diagonal struts and tie rods | 3200 | |
| Undercarriage UW 260.1, complete | | | 11400 |
| | ▪ Undercarriage platform with hinged sections, subframes and transport locks | 7150 | |
| | ▪ Mast base with diagonal struts and tie rods | 4250 | |
| Undercarriage UW 260.2, complete | | | 14060 |
| | ▪ Undercarriage platform with hinged sections, subframes and transport locks | 9810 | |
| | ▪ Mast base with diagonal struts and tie rods | 4250 | |
| Undercarriage UW 260.3, complete | | | 17200 |
| | ▪ Undercarriage platform with hinged sections, subframes and transport locks | 11300 | |
| | ▪ Mast base with diagonal struts and tie rods | 5900 | |
| Undercarriage UW 480, complete | | | 34000 |
| | ▪ Mast base | 7100 | |
| | ▪ Hinged sections with mounting device and subframes | 16000 | |
| | ▪ Diagonal struts and ballast carrier | 9260 | |
| | ▪ Assembly platform, ladder, and small parts | 1640 | |

7.8 Required hook height for mobile cranes

For information about the height of the WOLFF slewing tower crane, refer to Tower combinations [12].

NOTICE! During assembly, allowances must be made for level differences (mobile crane to base of the slewing tower crane).

Hook height above ground required for mobile cranes (X) = height of the WOLFF slewing tower crane (A) + clearance of 12 m (B).

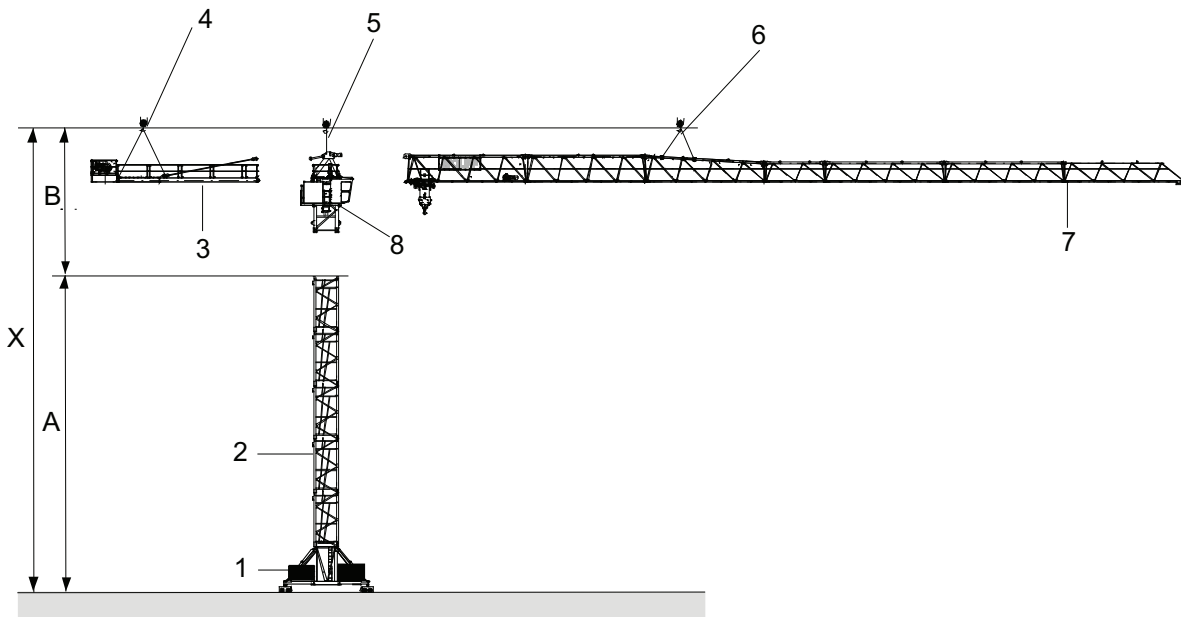

Exemplary illustration

| | | | |
|-----|--|-----|--|
| [A] | Height of the WOLFF slewing tower crane | [B] | Clearance 12 m |
| [X] | Hook height above ground required for the mobile crane | | |
| 1 | Undercarriage | 5 | Single-point lifting tackle (2 m with shackle) |
| 2 | Tower element | 6 | 4-fall attachment (4 m with shackle) |
| 3 | Counterjib, complete | 7 | Jib, complete |
| 4 | Four-point lifting tackle (with shackle) | 8 | Tower head section, complete |

(see also):

- Tower combinations [12]

8 Assembly diagrams

8 Assembly diagrams

8.1 Jib attachment diagram

| | |
|---|---|
|  | NOTICE |
| | For jib assembly, use a 4-fall attachment (4 m with shackle). |

| | |
|---|---|
|  | NOTICE |
| | To install the snatch block within two sling ropes to DIN 3088 (Ø 8 mm x 1 m with shackle), attach it to the trolley, reeve in the mounting rope (Perlon, Ø 14 mm x 12 m) and secure it on the trolley. |

Length of jib elements

| Item | Length [m] |
|---------------------------------------|------------|
| Trolley jib elements 1, 3, 6, 7 and 8 | 10.0 |
| Jib element 2, 4 | 5.0 |
| Trolley jib element 5 | 2.5 |
| Rope swivel crossbeam | 0.51 |

8.1.1 Trolley jib - attachment diagram 60 m to 50 m

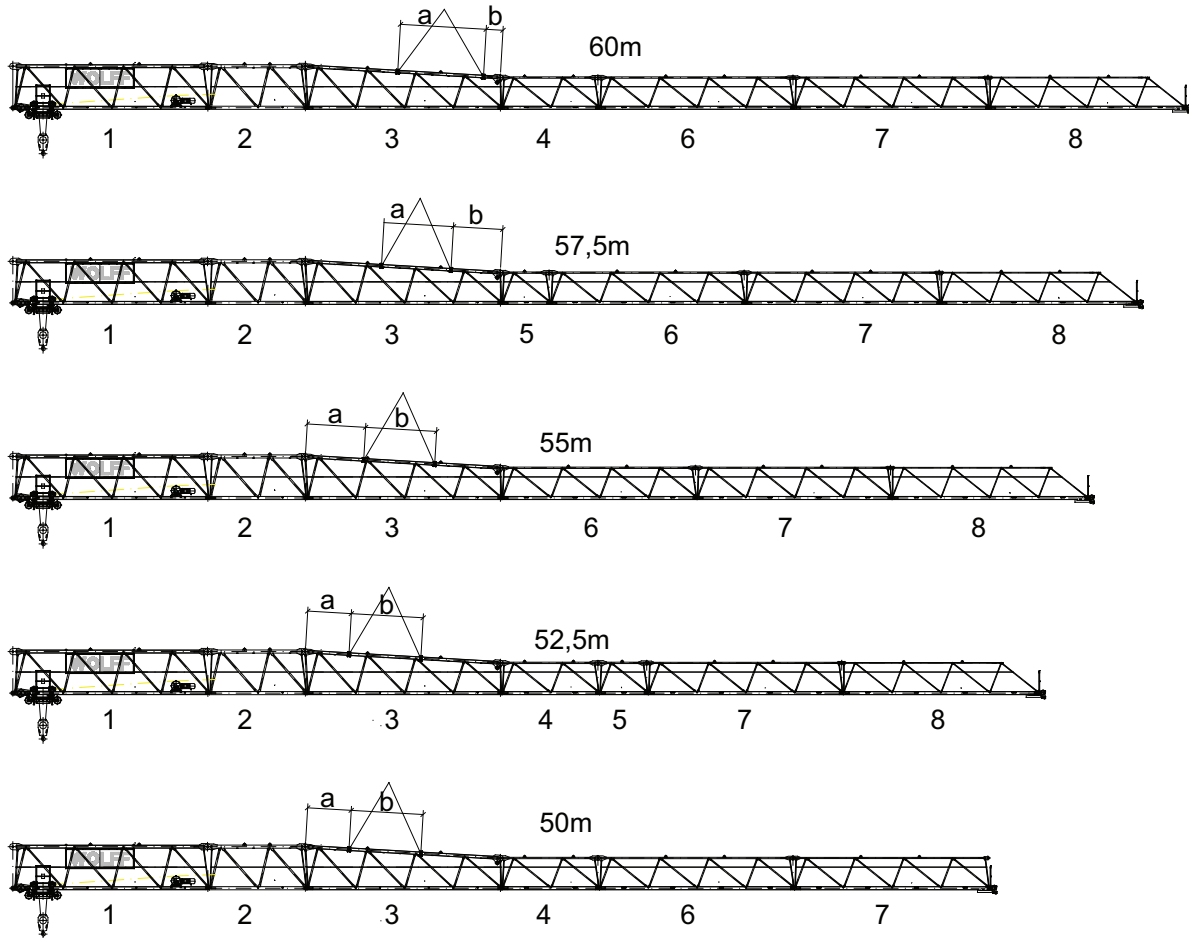

| | |
|---|-------------|
| a | Dimension a |
| b | Dimension b |

| Data | Jib length [m] | | | | |
|---------------------------|----------------|-------|------|------|------|
| | 60 | 57.5 | 55 | 52.5 | 50 |
| a [mm] | 4400 | 3600 | 3000 | 2200 | 2200 |
| b [mm] | 860 | 2500 | 3700 | 3700 | 3700 |
| Weight [kg] 6023 clear | 10400 | 10100 | 9620 | 9500 | 9600 |

8 Assembly diagrams

8.1.2 Trolley jib - attachment diagram 47.5 m to 37.5 m

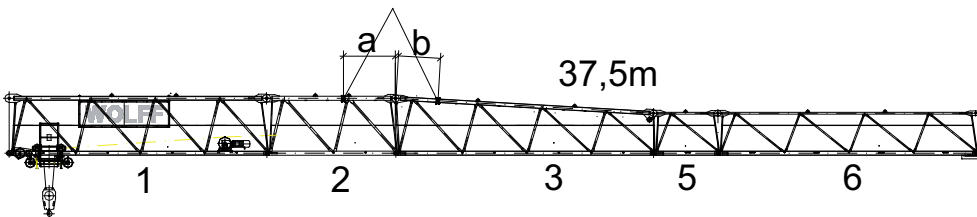
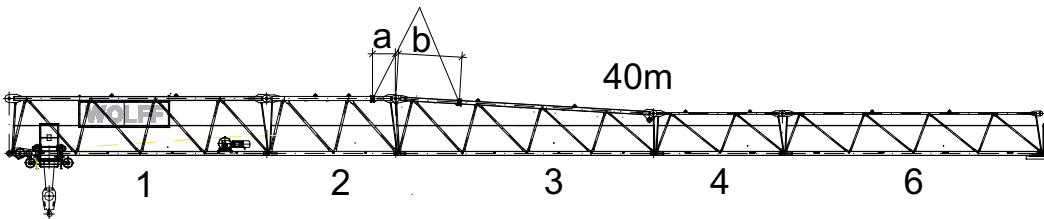
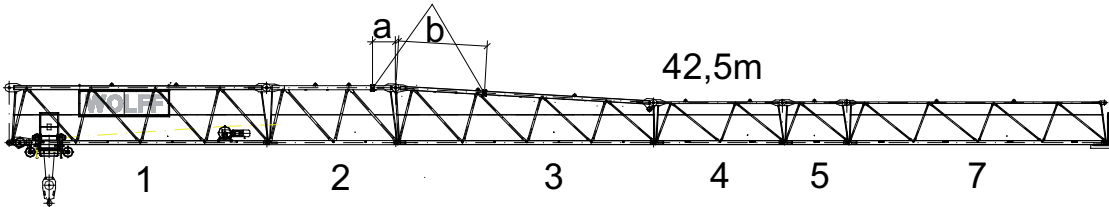
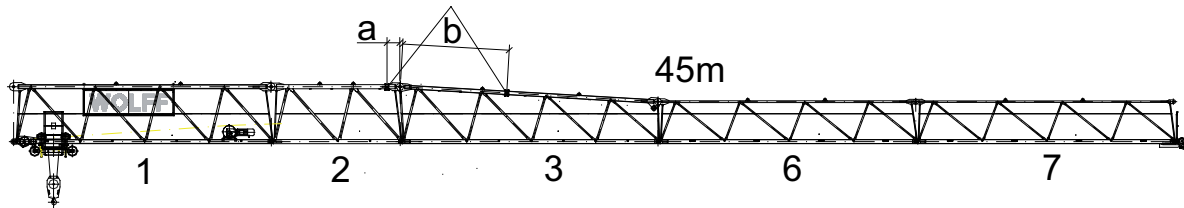
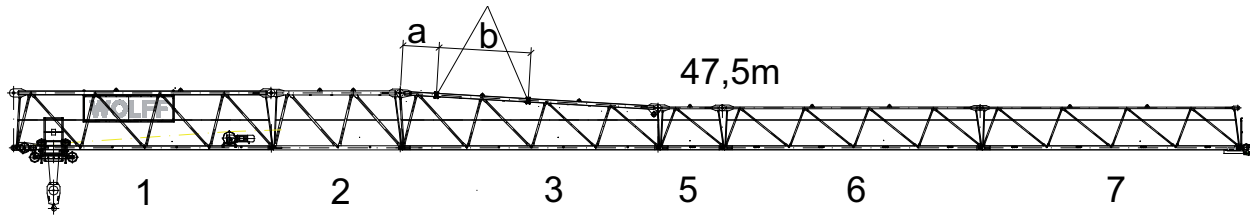

| | |
|---|-------------|
| a | Dimension a |
| b | Dimension b |

| Data | Jib length [m] | | | | |
|---------------------------|----------------|------|------|------|------|
| | 47.5 | 45 | 42.5 | 40 | 37.5 |
| a [mm] | 1400 | 500 | 900 | 900 | 2000 |
| b [mm] | 3600 | 4100 | 3400 | 2500 | 1700 |
| Weight [kg] 6023 clear | 9300 | 8820 | 8700 | 8550 | 8250 |

8.1.3 Trolley jib - attachment diagram 35 m to 25 m

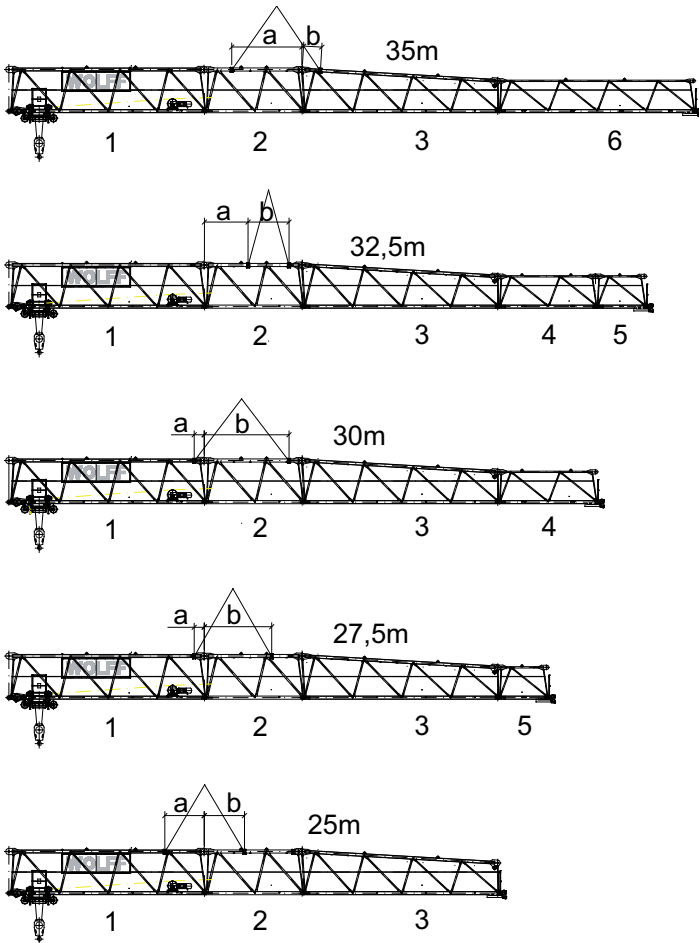

| | |
|---|-------------|
| a | Dimension a |
| b | Dimension b |

| Data | Jib length [m] | | | | |
|---------------------------|----------------|------|------|------|------|
| | 35 | 32.5 | 30 | 27.5 | 25 |
| a [mm] | 3600 | 2200 | 500 | 500 | 2000 |
| b [mm] | 1000 | 2100 | 4300 | 3400 | 2000 |
| Weight [kg] 6023 clear | 7770 | 7650 | 7170 | 6870 | 6390 |

8 Assembly diagrams

8.2 Trolley jib mounting rig

| | |
|---|--|
|  | NOTICE |
| | <p>For information on the arrangement of the mounting rig, refer to the attachment diagram.</p> <p>Two mounting rigs are required per slewing tower crane.</p> |

Elements required for each mounting rig

| Quantity | Item | Dimensions | Material |
|----------|---------------------|------------|-----------------------|
| 1 | Mounting rig | | |
| 4 | Hexagonal head bolt | M16 x 240 | ISO 4017-8.8 galv. |
| 8 | HSFG washer | 17 | EN 14399 galvanized |
| 8 | Hexagonal nut | M16 | ISO 4032-8 galvanized |

Mounting rig

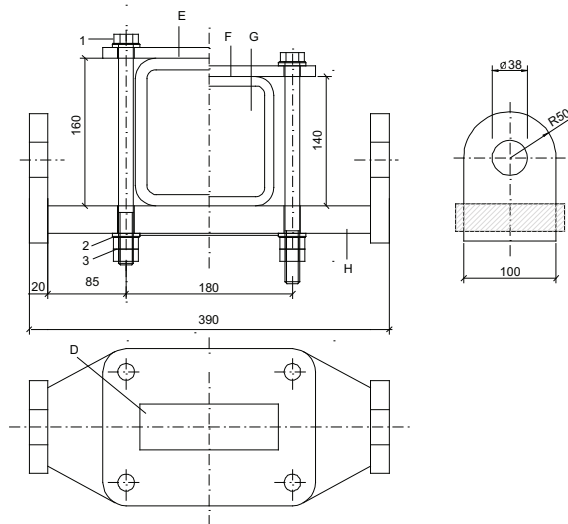

| | | | |
|---|----------------------|---|-----------------------|
| 1 | Hexagonal head screw | A | Mounting rig |
| 2 | HSFG washer | B | Top chord trolley jib |
| 3 | Hexagonal nut | | |

8.3 Arrangement of standard railings

8.3.1 Standard railings (NG) and accessories

| Quantity * | Standard railings (NG) |
|-------------------|---------------------------------|
| 5 | Standard post (NP) |
| 1 | NPF (standard posts with mount) |
| 1 | F * (flag pole mount) |
| 5 | Standard railing 500 |
| 1 | Standard railing 750 |
| 3 | Standard railing 1000 |
| 1 | NG 1000 with chafe guard |
| 2 | Standard railing 2000 |
| 8 | Standard railing 2500 |
| 1 | RS (hoop guard) |

8 Assembly diagrams

8.3.2 Arrangement of standard railings

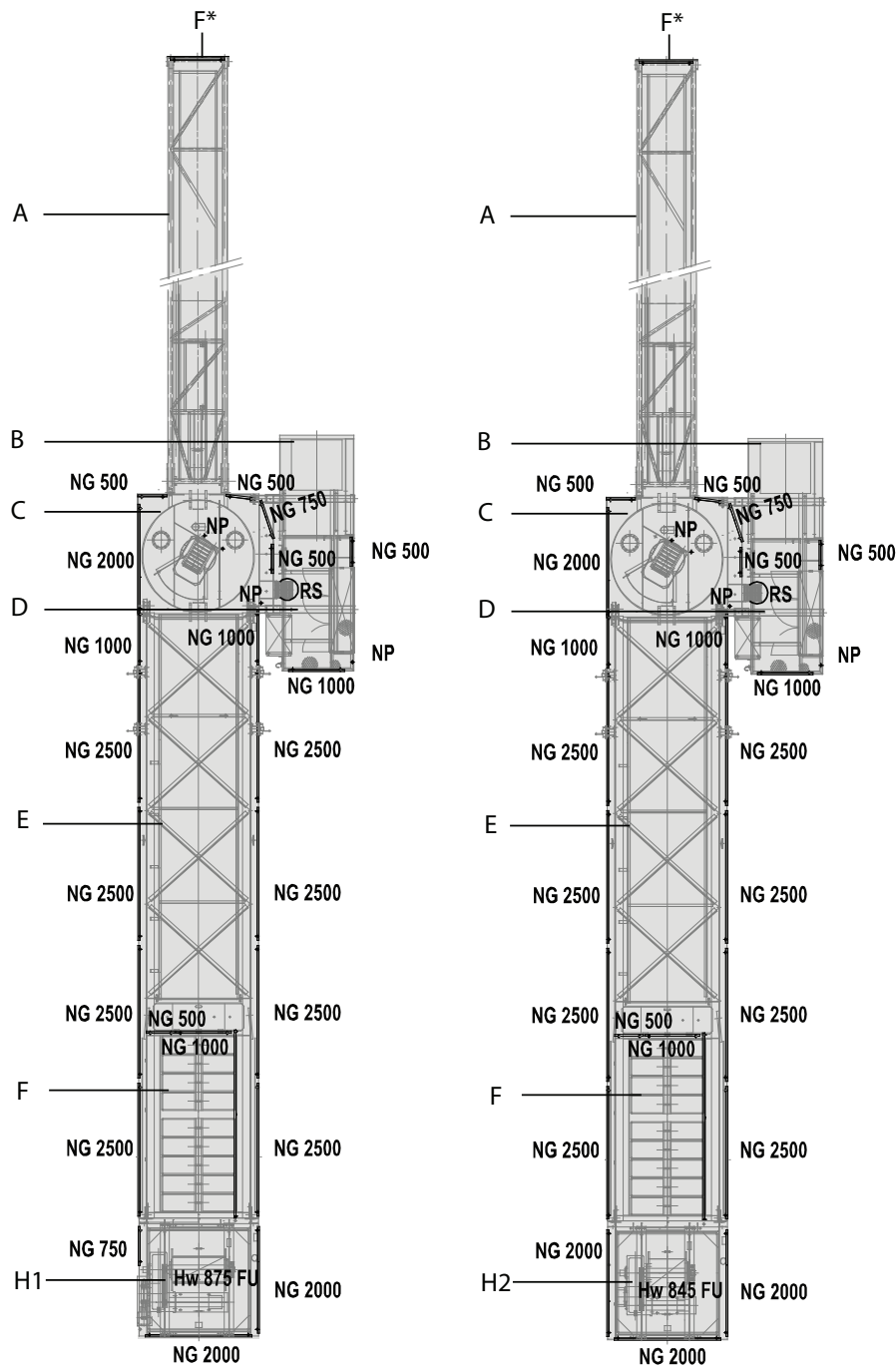

Arrangement of standard railings

| | | | |
|---|-------------------|-----|---------------------|
| A | Trolley jib | F | Counterweights |
| B | Driver's cab | H1 | Hoist winch Hw875FU |
| C | Cat head pedestal | H2 | Hoist winch Hw845FU |
| D | Control cabinet | H2 | Hoist winch Hw628FU |
| E | Counterjib | F * | Flag pole mount |

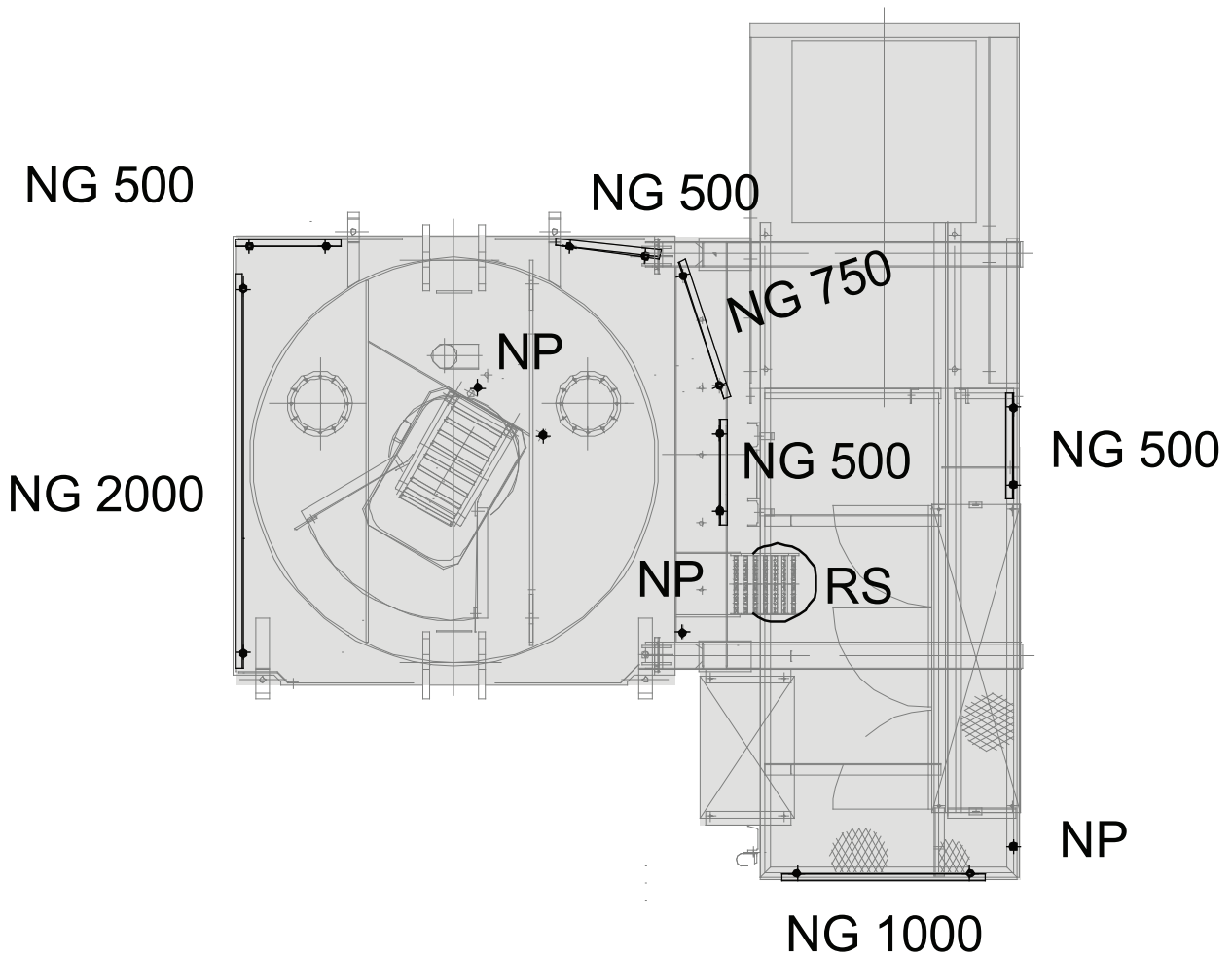

Arrangement of standard railings, tower head section

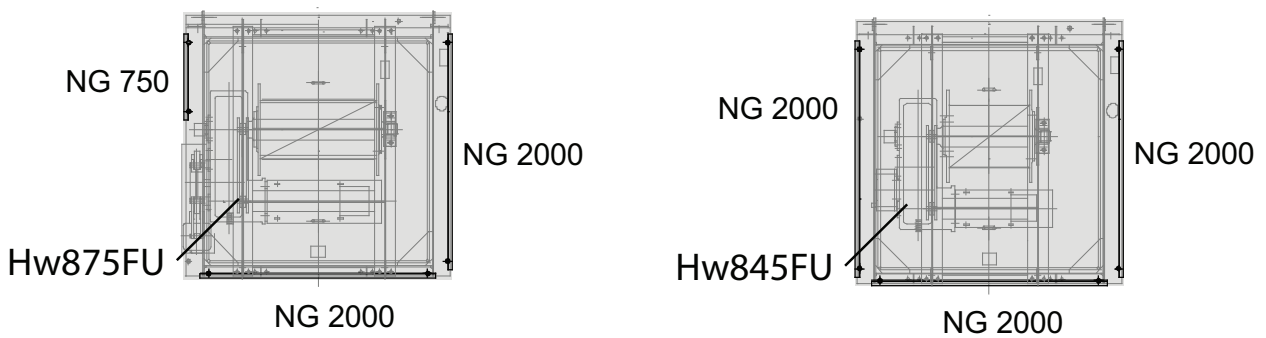

Arrangement of standard railings hoist winch





| | |
|---|--|
|  | NOTICE |
| | <p>The railing arrangement for Hw628FU is identical to that for Hw845FU.</p> |

9 Suitable climbing devices



9 Suitable climbing devices

This section contains information on

- Outer climbing devices (KWH)
- Inner climbing devices (KSH)

| | |
|---|---|
|  | <p style="text-align: center;">NOTICE</p> <p>Details on the climbing device Always refer to the details in the documentation of the climbing device.</p> |
|  | <p style="text-align: center;">NOTICE</p> <p>The operating radius specified is measured from the tower center and is to be considered a reference value. Exact balancing can be achieved by changing the operating radius with the tower elements or loads specified in the table.</p> |
|  | <p style="text-align: center;">NOTICE</p> <p>Details for climbing balancing The climbing balancing details apply to the snatch block in maximum hook position.</p> |
|  | <p style="text-align: center;">NOTICE</p> <p>If feasible, preferably operate your climbing device without balancing weight.</p> |

9.1 Outer climbing devices

| | |
|---|--|
|  | <p style="text-align: center;">! DANGER</p> <p>Climbing device attached to the lower part of the tower head section lower part.</p> <p>Increased wind surface. The slewing tower crane may overturn.</p> <ul style="list-style-type: none">▶ Dismantle the climbing device after the climbing procedure is finished or lower the climbing device down on the ground or lower the climbing device down to the uppermost tower brace. |
|  | <p style="text-align: center;">NOTICE</p> <p>Tower element on the transfer carriage</p> <p>The data on climbing balance was specified under the assumption that a tower element is on the transfer carriage.</p> |

9 Suitable climbing devices

9.1.1 Outer climbing device KWH 20.3 / KWH 20.3.1

Climbing radius for the balancing weights

| 6023 | Jib length [m] | | | | | | | | | | | | | | |
|----------------|----------------|------|------|------|------|------|------|------|------|------|------|------|------|------|------|
| | 60 | 57.5 | 55 | 52.5 | 50 | 47.5 | 45 | 42.5 | 40 | 37.5 | 35 | 32.5 | 30 | 27.5 | 25 |
| UV 20 = 1.95 t | 9.6 | 14.2 | 15.4 | 16.6 | 16.6 | 19.9 | 21.0 | 20.8 | 21.6 | 21.0 | 23.5 | 25.4 | 24.7 | - | - |
| TV 20 = 3.05 t | 6.1 | 9.6 | 10.4 | 11.4 | 11.4 | 13.9 | 14.7 | 14.6 | 15.2 | 14.8 | 16.6 | 18.1 | 17.6 | 18.5 | 16.0 |

9.1.2 Außenkletterwerk KWH 20.6 / KWH 20.6.1 / KWH 20.6.2

Climbing radius for the balancing weights

| 6023 | Jib length [m] | | | | | | | | | | | | | | |
|----------------|----------------|------|------|------|------|------|------|------|------|------|------|------|------|------|------|
| | 60 | 57.5 | 55 | 52.5 | 50 | 47.5 | 45 | 42.5 | 40 | 37.5 | 35 | 32.5 | 30 | 27.5 | 25 |
| UV 20 = 1.95 t | 8.8 | 13.4 | 14.5 | 15.8 | 15.8 | 19.1 | 20.1 | 20.0 | 20.8 | 20.2 | 22.7 | 24.6 | 23.9 | - | - |
| TV 20 = 3.05 t | 5.4 | 9.0 | 9.8 | 10.7 | 10.8 | 13.2 | 14.1 | 14.0 | 14.6 | 14.1 | 16.0 | 17.4 | 17.0 | 17.9 | 15.4 |

9 Suitable climbing devices

9.2 Inner climbing devices

| | |
|---|---|
|  | NOTICE |
| | The data required and the instructions for tower assemblies with inner climbing device is available in the separate description of the inner climbing device. |

DANGER! Observe the special tower combination for the inner climbing device.

| | |
|---|--|
|  | NOTICE |
| | Clamping forces for the inner climbing device (KSH) are specified based on a building height of < 250m and wind category C 25. |

9.2.1 Inner climbing device KSH 20 M

Tower combinations for slewing tower cranes with inner climbing device.

| Item | | |
|------------------------------|------------|------------|
| 1 | UV 20.4 LC | UV 20.4 |
| 2 | UV 20.4 LC | UV 20.4 LC |
| 3 | | UV 20.4 LC |
| inner climbing device | KSH 20 M | KSH 20 M |
| Foundation | FUA 120 | FUA 120 |
| Tower height [m] | 37.5 | 42.0 |
| Hook height above ground [m] | 39.0 | 43.5 |

Climbing radius for the balancing weights

| | Jib length [m] | | | | | | | | | | | | | | |
|---------------------|----------------|------|------|------|------|------|------|------|------|------|------|------|------|------|------|
| | 60 | 57.5 | 55 | 52.5 | 50 | 47.5 | 45 | 42.5 | 40 | 37.5 | 35 | 32.5 | 30 | 27.5 | 25 |
| UV 20.4 = 2.05 t | 37.3 | 41.8 | 41.6 | 42.7 | 42.8 | - | - | - | - | - | - | - | - | - | - |
| TV 20.4 = 2.98 t | 28.3 | 31.8 | 31.6 | 32.5 | 32.6 | 34.9 | 34.7 | 34.6 | 35.2 | 33.7 | - | - | - | - | - |
| Weight = 5.00 t | 18.3 | 20.5 | 20.4 | 21.0 | 21.0 | 22.6 | 22.5 | 22.4 | 22.7 | 21.8 | 22.9 | 23.8 | 22.8 | 23.4 | 21.1 |

9 Suitable climbing devices

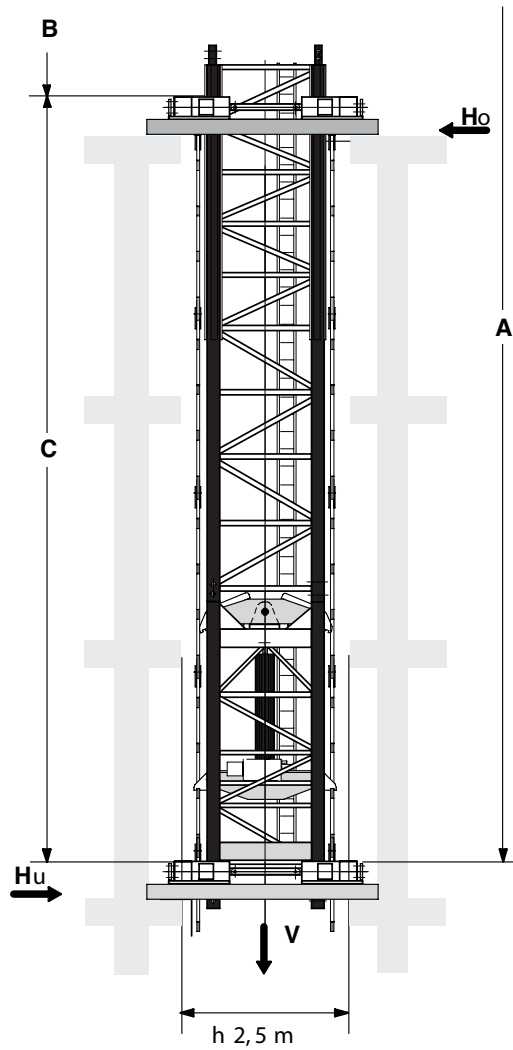

$$C_{\min} = 11,0 \text{ m}$$

$$C_{\max} = 14,0 \text{ m}$$

$$H_o = \frac{M}{C} + H$$

$$H_u = H_o - H$$

$$T = \frac{M_D}{2 \times a}$$

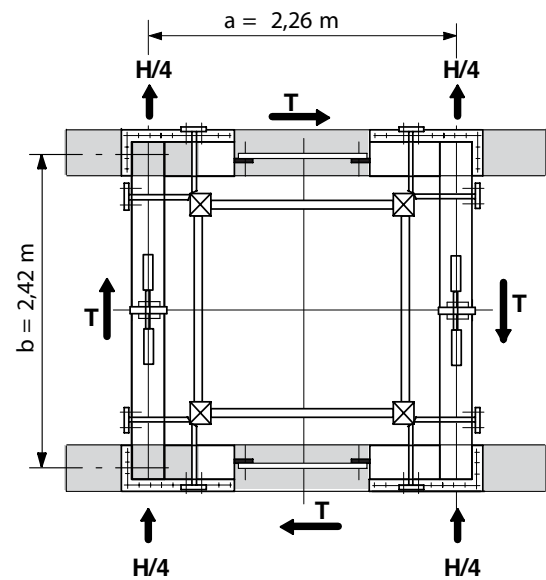

| | | | |
|---|--------------|---|-------------------------------|
| A | tower height | C | Distance between guide frames |
| B | A-C-D | D | 0.77 m |

In service clamping forces

| In service clamping forces [kN] inside a building | | | | | | | | |
|---|------|-----|-----|-----|------|-----|-----|-----|
| A [m] | 42.0 | | | | 37.5 | | | |
| C [m] | 11 | 12 | 13 | 14 | 11 | 12 | 13 | 14 |
| V | 844 | | | | 830 | | | |
| Ho | 230 | 210 | 200 | 180 | 220 | 200 | 190 | 170 |
| Hu | 200 | 180 | 170 | 150 | 190 | 170 | 160 | 140 |
| T | 44 | | | | 44 | | | |

Out of service clamping forces

| Out of service clamping forces [kN] inside a building | | | | | | | | |
|---|------|-----|-----|-----|------|-----|-----|-----|
| A [m] | 42.0 | | | | 37.5 | | | |
| C [m] | 11 | 12 | 13 | 14 | 11 | 12 | 13 | 14 |
| V | 750 | | | | 736 | | | |
| Ho | 360 | 330 | 310 | 290 | 300 | 280 | 260 | 240 |
| Hu | 210 | 180 | 160 | 140 | 160 | 140 | 120 | 100 |
| T | 0 | | | | 0 | | | |

9.2.2 Inner climbing device KSH 20 SH

Tower combinations for slewing tower cranes with inner climbing device.

| Item | | | | |
|------------------------------|----------------------------|----------------------------|----------------------------|----------------------------|
| 1 | UV 20.4 | UV 20.4 | UV 20.4 | UV 20.4 |
| 2 | UV 20.4 | UV 20.4 | UV 20.4 | UV 20.4 |
| 3 | UV 20.4 | UV 20.4 | UV 20.4 | UV 20.4 |
| 4 | UV 20.4 | UV 20.4 | UV 20.4 | UV 20.4 |
| 5 | UV 20.4 | UV 20.4 | UV 20.4 | UV 20.4 |
| 6 | UV 20.4 | UV 20.4 | UV 20.4 | UV 20.4 |
| 7 | TVA 20.4 | UV 20.4 | UV 20.4 | UV 20.4 |
| 8 | | TVA 20.4 | UV 20.4 | UV 20.4 |
| 9 | | | TVA 20.4 | UV 20.4 |
| 10 | | | | TVA 20.4 |
| inner climbing device | KSH 20 SH | KSH 20 SH | KSH 20 SH | KSH 20 SH |
| Foundation anchors | FUA TYPE FS-156 / FUA 156S | FUA TYPE FS-156 / FUA 156S | FUA TYPE FS-156 / FUA 156S | FUA TYPE FS-156 / FUA 156S |
| Tower height [m] | 46.5 | 51.0 | 55.5 | 60.0 |
| Hook height above ground [m] | 48.0 | 52.5 | 57.0 | 61.5 |

Climbing radius [m] for the balancing weights

| | Jib length [m] | | | | | | | | | | | | | | |
|------------------|----------------|------|------|------|------|------|------|------|------|------|------|------|------|------|------|
| | 60 | 57.5 | 55 | 52.5 | 50 | 47.5 | 45 | 42.5 | 40 | 37.5 | 35 | 32.5 | 30 | 27.5 | 25 |
| UV 20.4 = 2.05 t | 37.3 | 41.8 | 41.6 | 42.7 | 42.8 | - | - | - | - | - | - | - | - | - | - |
| TV 20.4 = 2.98 t | 28.3 | 31.8 | 31.6 | 32.5 | 32.6 | 34.9 | 34.7 | 34.6 | 35.2 | 33.7 | - | - | - | - | - |
| Weight = 5.00 t | 18.3 | 20.5 | 20.4 | 21.0 | 21.0 | 22.6 | 22.5 | 22.4 | 22.7 | 21.8 | 22.9 | 23.8 | 22.8 | 23.4 | 21.1 |

9 Suitable climbing devices

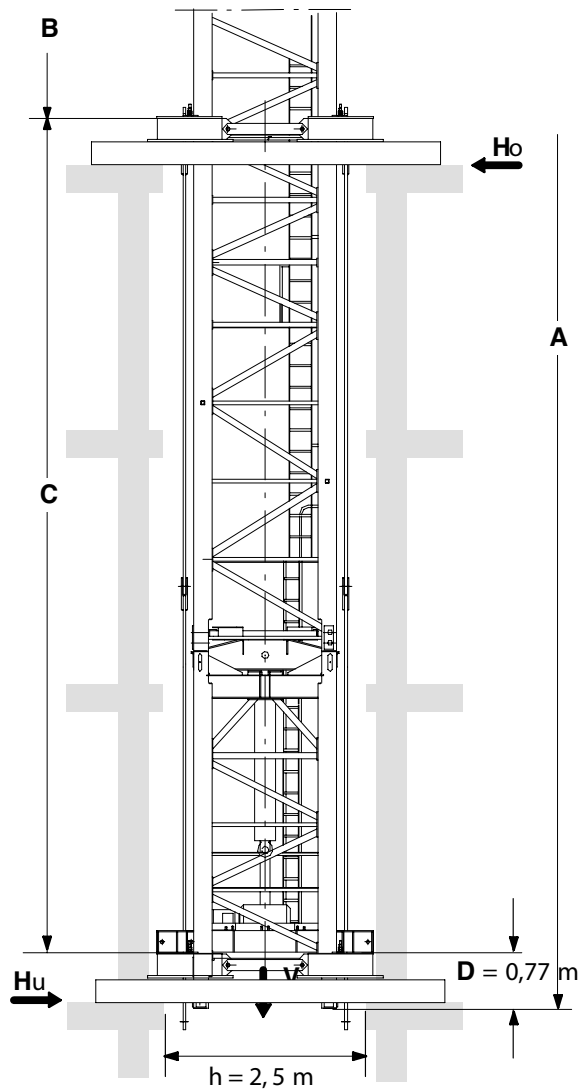

$$C_{\min} = 11,0 \text{ m}$$

$$C_{\max} = 14,0 \text{ m}$$

$$H_o = \frac{M}{C} + H$$

$$H_u = H_o - H$$

$$T = \frac{M_D}{2 \times b}$$

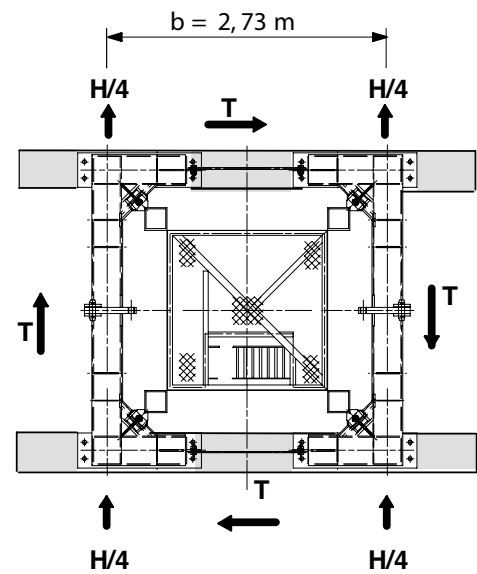

| | | | |
|---|--------------|---|-------------------------------|
| A | Tower height | C | Distance between guide frames |
| B | A-C-D | | |

Einspannkräfte in Betrieb

| Einspannkräfte im Gebäude [kN] in Betrieb | | | | | | | | | | | | | | | | |
|---|-----|-----|-----|-----|------|-----|-----|-----|-----|-----|-----|-----|------|-----|-----|-----|
| A [m] | 60 | | | | 55,5 | | | | 51 | | | | 46,5 | | | |
| C [m] | 11 | 12 | 13 | 14 | 11 | 12 | 13 | 14 | 11 | 12 | 13 | 14 | 11 | 12 | 13 | 14 |
| V | 959 | | | | 941 | | | | 927 | | | | 913 | | | |
| Ho | 300 | 280 | 260 | 240 | 280 | 260 | 240 | 220 | 260 | 240 | 220 | 210 | 240 | 220 | 210 | 190 |
| Hu | 270 | 240 | 220 | 200 | 250 | 220 | 200 | 180 | 230 | 210 | 190 | 180 | 210 | 190 | 180 | 160 |
| T | 44 | | | | 44 | | | | 44 | | | | 44 | | | |

Einspannkräfte außer Betrieb

| Einspannkräfte im Gebäude [kN] außer Betrieb | | | | | | | | | | | | | | | | |
|--|-----|-----|-----|-----|------|-----|-----|-----|-----|-----|-----|-----|------|-----|-----|-----|
| A [m] | 60 | | | | 55,5 | | | | 51 | | | | 46,5 | | | |
| C [m] | 11 | 12 | 13 | 14 | 11 | 12 | 13 | 14 | 11 | 12 | 13 | 14 | 11 | 12 | 13 | 14 |
| V | 866 | | | | 847 | | | | 833 | | | | 819 | | | |
| Ho | 660 | 610 | 560 | 520 | 580 | 530 | 490 | 450 | 500 | 460 | 420 | 390 | 430 | 390 | 360 | 340 |
| Hu | 470 | 420 | 370 | 330 | 400 | 350 | 310 | 270 | 330 | 290 | 250 | 220 | 270 | 230 | 200 | 180 |
| T | 0 | | | | 0 | | | | 0 | | | | 0 | | | |

10 Arrangement of counterweight blocks

10 Arrangement of counterweight blocks

| | | | | |
|-------------------|-------------------|-------------------|-------------------|-------------------|
| L = 60.0 m | L = 57.5 m | L = 55.0 m | L = 52.5 m | L = 50.0 m |
| 7 x 2.7 t | 7 x 2.7 t | 6 x 2.7 t | 6 x 2.7 t | 6 x 2.7 t |
| | | | | |
| W = 22.6 t | W = 22.6 t | W = 19.9 t | W = 19.9 t | W = 19.9 t |
| L = 47.5 m | L = 45.0 m | L = 42.5 m | L = 40.0 m | L = 37.5 m |
| 6 x 2.7 t | 5 x 2.7 t | 5 x 2.7 t | 5 x 2.7 t | 4 x 2.7 t |
| | | | | |
| W = 19.9 t | W = 17.2 t | W = 17.2 t | W = 17.2 t | W = 14.5 t |
| L = 35.0 m | L = 32.5 m | L = 30.0 m | L = 27.5 m | L = 25.0 m |
| 4 x 2.7 t | 4 x 2.7 t | 3 x 2.7 t | 3 x 2.7 t | 2 x 2.7 t |
| | | | | |
| W = 14.5 t | W = 14.5 t | W = 11.8 t | W = 11.8 t | W = 9.1 t |

Additional permanent counterweight for all jib lengths: 3.7 t

| | | | |
|---|------------------|---|---------------|
| L | Jib length [m] | a | To the tower |
| G | Total weight [t] | | Counterweight |
| | No counterweight | | |

WOLFFKRAN Group

Headquarter international:

WOLFFKRAN AG

Baarermattstraße 6

CH-6300 Zug

Switzerland

Phone +41 41 766 85 00

Fax +41 41 766 85 99

info@wolffkran.com

Manufacturing:

WOLFFKRAN GmbH

Austraße 72

D-74076 Heilbronn

Germany

Phone + 49 7131 9815 0

Fax + 49 7131 9815 355

info@wolffkran.de

WOLFFKRAN Werk Brandenburg GmbH

Frederik-Ipsen-Straße 5

D-15926 Luckau OT Altno

Germany

Phone + 49 35456 674 0

Fax + 49 35456 674 200

info@wolffkran.de